



RG5FT/EN SPECIFICATIONS

ATEIS EUROPE B.V.

Website: www.ateis-europe.com

Sydneystraat 42, ROTTERDAM, 3047 BP, Netherlands. Tel: 31-10-2088690



RoHS

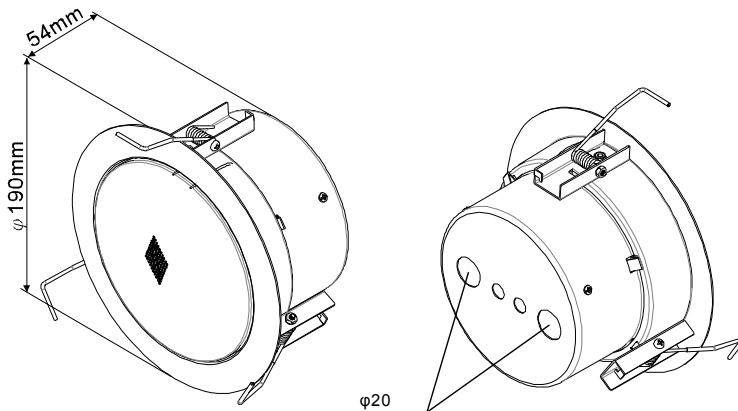

EN54-24:2008
0359-CPD-0137
TYPE A

With Transformer:

100V/70V line

	White wire plus tapping					Black
100V	0.25W	0.75W	1.5W	3W	6W	COM
70V	0.125W	0.375W	0.75W	1.5W	3W	COM
IMP.(Ω)	40k	13.3k	6.67k	3.33k	1.67k	

Technical Specifications

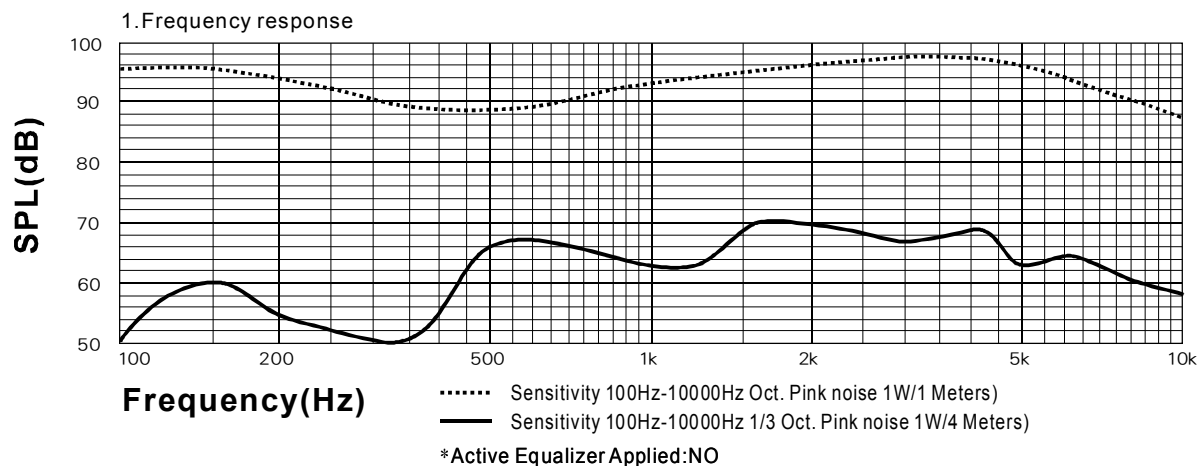

2. Horizontal coverage angles = Vertical angles

		Horizontal	Vertical
1 Oct. Pink noise	500 Hz	180°	180°
1 Oct. Pink noise	1K Hz	180°	180°
1 Oct. Pink noise	2K Hz	120°	120°
1 Oct. Pink noise	4K Hz	80°	80°

3. Environmental

IP-rating.....21
 Max/Min amb temp.....55 °C / -10 °C
 Relative humidity.....≤95%

4. Electrical

Rated power, Watts 6
 Tappings 100 volt line, Watts 6/3/1.5/0.75/0.25
 Transformer Impedance, Ohms 100V 1.67k/3.33k/6.67k/13.3k/40k
 Tappings 70.7 volt line, Watts 3/1.5/0.75/0.375/0.125
 Driver impedance, Ohms 8
 Effective Frequency Range, Hz (BSEN60268-5) 100-17,500
 S.P.L. @ 4m, 1watt, dB, 1/3 Octave, 1KHz 63
 S.P.L. @ 1m, 1watt, dB, Octave 1KHz 87
 S.P.L. @ 4m, Full power, dB, 1/3 Octave 1KHz 71
 S.P.L. @ 1m, Full power, Octave 1KHz 95

5. Mechanical

Dimensions φ 190mm
 Net weight, Kgs 1.1
 Colour (Unless Specified) RAL9016
 Material Steel, White Paint
 Mounting Bayonet System with 3 spring
 Cut-out, mm φ 172

RGS 5FT/EN has been tested in 100 hours max power (6W). The model does not deviate more than ± 3dB from the original test value. The freq. response curve and impedance complies with the original one. All SPL tests are performed in a anechoic chamber (<70m/3).

➤ RGS 5FT/EN

INSTALLATION GUIDE

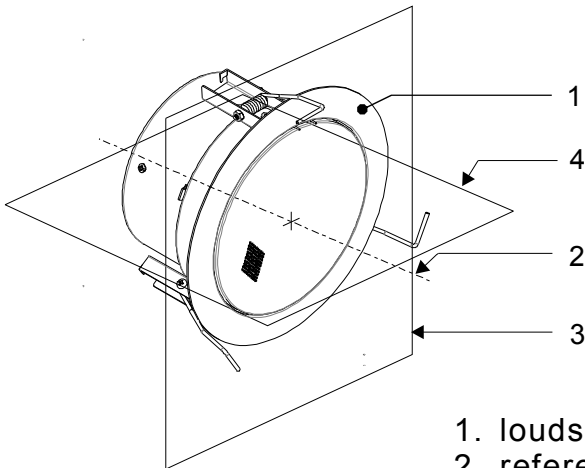

- 1. loudspeaker enclosure
- 2. reference axis
- 3. reference plane
- 4. horizontal plane

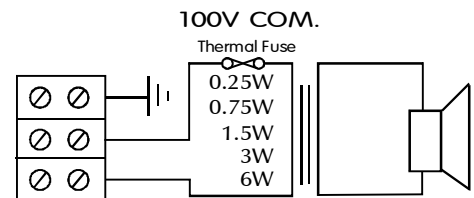

Circuit Diagram

RGS 5FT/EN

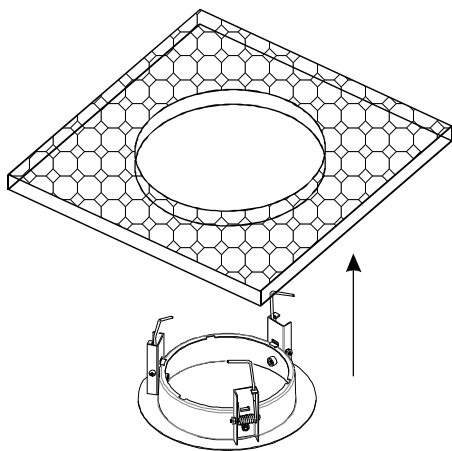

1. Cut a Hole at floor and set up the RGS Frame.

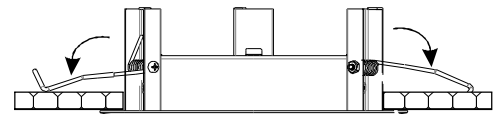

2. Relieve the springs

Choose one of them (Holes).

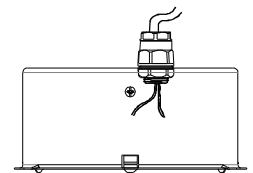
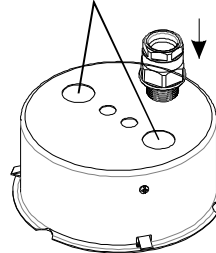

3. Punch the hole and screw the Gland.

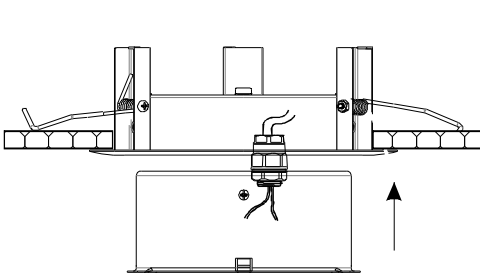

4. Push up the dome until lock it.

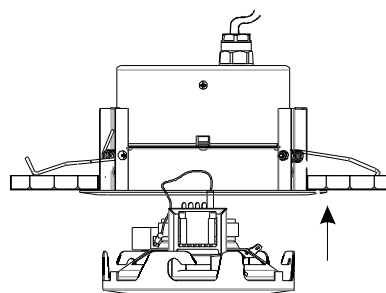

4. Push the Speaker up to the top and rotation it.

