



VG4 Modular Camera Series

VG4 Series



BOSCH

en Installation Manual

Table of Contents

1	Safety	6
1.1	Important Safety Instructions	6
1.2	Safety Precautions	8
1.3	Important Safeguards for Pressurized Units	8
1.4	Important Notices	8
1.5	Customer Support and Service	12
2	Installing the Pendant Arm Wall, Corner, and Mast (Pole) Mounts	13
2.1	Unpacking	13
2.1.1	Parts List	13
2.1.2	Description	15
2.1.3	Tools Required	15
2.2	Pre-installation Checklist	15
2.3	Mount Power Supply Box	16
2.4	Route Wires and Attach Connectors	17
2.4.1	Power Supply Box Connections	20
2.5	Route Power through Intermediate Power Supply Box	21
2.6	Attach Pendant Arm to Power Supply Box	24
2.7	Make Connections in Power Supply Box	25
2.8	Installing the VG4-A-ARMPLATE	27
2.8.1	Attach the Pendant Arm to the Mounting Plate	28
2.8.2	Route and Connect Wires to a Power Supply Box	29
2.9	Assemble Pendant in Packing Box	31
2.10	Attach Pendant to Arm and Tighten	33
2.11	Installing the Pressurized Environmental Housing	35
2.11.1	Important Installation Safeguards	35
2.11.2	VG4 Pressurized Environmental Housing	35
2.11.3	Required Equipment	36
2.11.4	Attaching the Housing to the Arm	37
2.11.5	Calibrating the Pressure Sensor	38
2.11.6	Attaching the Bubble to the Housing	39
2.11.7	Pressurizing the Housing	41
2.11.8	Servicing the VG4 Pressurized Environmental Housing	41
3	Installing Roof Parapet and Pipe Mounts	42
3.1	Unpacking	42
3.1.1	Parts List	42
3.1.2	Description	44
3.1.3	Tools Required	44
3.2	Pre-installation Check List	44
3.3	Mount Power Supply Box	45
3.3.1	Attach Cover Door	46
3.4	Route Wires and Attach Connectors	47
3.4.1	Wiring the Power Supply Box	49
3.4.2	Wiring the Fiber Optic Model	49
3.4.3	Power Supply Box Connections	51

3.5	Installing the VG4-A-9230 Roof Parapet Mount	52
3.6	Installing the VG4-A-9543 Pipe Mount	55
3.7	Wire the Pipe Interface Board	57
3.7.1	Wiring for Multiple AutoDomes	58
3.7.2	Connecting Wires to the Pipe Interface Board	58
3.8	Assemble the Pendant in Packing Box	60
3.9	Attach Pendant to Pipe and Tighten	62
3.10	Make Connections in the Power Supply Box	63
3.10.1	Connections for Fiber Optic Models	63
3.11	Installing the Pressurized Environmental Housing	65
3.11.1	Important Installation Safeguards	65
3.11.2	VG4 Pressurized Environmental Housing	65
3.11.3	Required Equipment	66
3.11.4	Attaching the Housing to the Pipe	67
3.11.5	Make Connections in the Power Supply Box	68
3.11.6	Calibrating the Pressure Sensor	69
3.11.7	Attaching the Bubble to the Housing	70
3.11.8	Pressurizing the Housing	72
3.11.9	Servicing the Pressurized Environmental Housing installation	72
4	Installing the In-Ceiling Mount	73
4.1	Unpacking	73
4.1.1	Parts List	73
4.1.2	Description	74
4.1.3	Tools Required	74
4.2	Pre-installation Check List	75
4.3	Dimensions	75
4.4	Prepare Drywall Ceiling for Installation	75
4.5	Prepare Suspension Ceiling for Installation	76
4.6	Wire the Interface Box	78
4.6.1	Interface Box Connections	80
4.7	Attach Housing to the Interface Box	81
4.8	Secure Housing to Ceiling	82
4.9	Align and Install Camera Module	83
4.10	Attach Bubble	83
5	Cable and Wire Standards	85
5.1	Power	85
5.2	Wire Distance Guide for Pendant	85
5.3	Video and Control Cables	85
5.4	Control-only Cables	88
5.5	Fiber Optic Module with an RS232/RS422 Controller	92
5.5.1	Connecting to an LTC 4629 Head End Data/Video Transceiver	92
5.5.2	Configuring the VG4 AutoDome	93

5.6	Audio Cables	94
6	Alarms and Relay Connections	96
6.1	Alarm Inputs	96
6.2	Configuring Supervised Alarms (inputs 1 and 2)	96
6.2.1	Configuring a Normally Open Supervised Alarm	96
6.2.2	Configuring a Normally Closed Supervised Alarm	97
6.3	Configuring Non-supervised Alarms (inputs 1 through 7)	98
6.3.1	Configuring a Normally Open Non-supervised Alarm	98
6.3.2	Configuring a Normally Closed Non-supervised Alarm	98
6.4	Alarm Outputs	99
6.4.1	Configuring a Dry Contact Relay	99
6.4.2	Configuring an Open Collector Output	99
7	Bubble Handling and Cleaning	100
7.1	Handling	100
7.2	Cleaning	100
7.2.1	Cleaning the Bubble Interior	100
7.2.2	Cleaning the Bubble Exterior	100
A	Installation Notes for AutoTracker	101
A.1	Camera Height	101
A.2	Mount/Mounting Surfaces	102
A.3	Field of View	102
A.4	Unwanted Motion	102
	Index	103

1 Safety

1.1 Important Safety Instructions

Read, follow, and retain for future reference all of the following safety instructions. Heed all warnings on the unit and in the operating instructions before operating the unit.

1. **Cleaning** - Unplug the unit from the outlet before cleaning. Follow any instructions provided with the unit. Generally, using a dry cloth for cleaning is sufficient, but a moist fluff-free cloth or leather shammy may also be used. Do not use liquid cleaners or aerosol cleaners.
2. **Heat Sources** - Do not install the unit near any heat sources such as radiators, heaters, stoves, or other equipment (including amplifiers) that produce heat.
3. **Ventilation** - Any openings in the unit enclosure are provided for ventilation to prevent overheating and ensure reliable operation. Do not block or cover these openings. Do not place the unit in an enclosure unless proper ventilation is provided, or the manufacturer's instructions have been adhered to.
4. **Water** - Do not use this unit near water, for example near a bathtub, washbowl, sink, laundry basket, in a damp or wet basement, near a swimming pool, in an outdoor installation, or in any area classified as a wet location. To reduce the risk of fire or electrical shock, do not expose this unit to rain or moisture.
5. **Object and liquid entry** - Never push objects of any kind into this unit through openings as they may touch dangerous voltage points or short-out parts that could result in a fire or electrical shock. Never spill liquid of any kind on the unit. Do not place objects filled with liquids, such as vases or cups, on the unit.
6. **Lightning** - For added protection during a lightning storm, or when leaving this unit unattended and unused for long periods, unplug the unit from the wall outlet and disconnect the cable system. This will prevent damage to the unit from lightning and power line surges.
7. **Controls adjustment** - Adjust only those controls specified in the operating instructions. Improper adjustment of other controls may cause damage to the unit. Use of controls or adjustments, or performance of procedures other than those specified, may result in hazardous radiation exposure.
8. **Overloading** - Do not overload outlets and extension cords. This can cause fire or electrical shock.
9. **Power cord and plug protection** - Protect the plug and power cord from foot traffic, being pinched by items placed upon or against them at electrical outlets, and its exit from the unit. For units intended to operate with 230 VAC, 50 Hz, the input and output power cord must comply with the latest versions of *IEC Publication 227* or *IEC Publication 245*.
10. **Power disconnect** - Units with or without ON/OFF switches have power supplied to the unit whenever the power cord is inserted into the power source; however, the unit is operational only when the ON/OFF switch is in the ON position. The power cord is the main power disconnect device for switching off the voltage for all units.

11. **Power sources** - Operate the unit only from the type of power source indicated on the label. Before proceeding, be sure to disconnect the power from the cable to be installed into the unit.
 - For battery powered units, refer to the operating instructions.
 - For external power supplied units, use only the recommended or approved power supplies.
 - For limited power source units, this power source must comply with *EN60950*. Substitutions may damage the unit or cause fire or shock.
 - For 24 VAC units, voltage applied to the unit's power input should not exceed $\pm 10\%$, or 28 VAC. User-supplied wiring must comply with local electrical codes (Class 2 power levels). Do not ground the supply at the terminals or at the unit's power supply terminals.
 - If unsure of the type of power supply to use, contact your dealer or local power company.
12. **Servicing** - Do not attempt to service this unit yourself. Opening or removing covers may expose you to dangerous voltage or other hazards. Refer all servicing to qualified service personnel.
13. **Damage requiring service** - Unplug the unit from the main AC power source and refer servicing to qualified service personnel when any damage to the equipment has occurred, such as:
 - the power supply cord or plug is damaged;
 - exposure to moisture, water, and/or inclement weather (rain, snow, etc.);
 - liquid has been spilled in or on the equipment;
 - an object has fallen into the unit;
 - unit has been dropped or the unit cabinet is damaged;
 - unit exhibits a distinct change in performance;
 - unit does not operate normally when the user correctly follows the operating instructions.
14. **Replacement parts** - Be sure the service technician uses replacement parts specified by the manufacturer, or that have the same characteristics as the original parts. Unauthorized substitutions may cause fire, electrical shock, or other hazards.
15. **Safety check** - Safety checks should be performed upon completion of service or repairs to the unit to ensure proper operating condition.
16. **Installation** - Install in accordance with the manufacturer's instructions and in accordance with applicable local codes.
17. **Attachments, changes or modifications** - Only use attachments/accessories specified by the manufacturer. Any change or modification of the equipment, not expressly approved by Bosch, could void the warranty or, in the case of an authorization agreement, authority to operate the equipment.

1.2 Safety Precautions



DANGER!

This symbol indicates an imminently hazardous situation such as “Dangerous Voltage” inside the product. If not avoided, this will result in an electrical shock, serious bodily injury, or death.



WARNING!

Indicates a potentially hazardous situation. If not avoided, this could result in serious bodily injury or death.

CAUTION!

Indicates a potentially hazardous situation. If not avoided, this may result in minor or moderate injury. Alerts the user to important instructions accompanying the unit.



CAUTION!

Indicates a potentially hazardous situation. If not avoided, this may result in property damage or risk of damage to the unit.



NOTICE!

This symbol indicates information or a company policy that relates directly or indirectly to the safety of personnel or protection of property.

1.3 Important Safeguards for Pressurized Units

- Always use safety goggles when servicing the unit.
- Never use an unregulated gas supply to pressurize the enclosure. The valve should be regulated with a maximum of 70 kPa (10 psi) output.
- PRESSURIZE USING DRY NITROGEN ONLY!



CAUTION!

Be sure to periodically examine the unit and its supporting structure. If the dome shows any signs of wear, such as stress cracking, it should be replaced immediately.

1.4 Important Notices



Accessories - Do not place this unit on an unstable stand, tripod, bracket, or mount. The unit may fall, causing serious injury and/or serious damage to the unit. Use only with the cart, stand, tripod, bracket, or table specified by the manufacturer. When a cart is used, use caution and care when moving the cart/apparatus combination to avoid injury from tip-over. Quick stops, excessive force, or uneven surfaces may cause the cart/unit combination to overturn. Mount the unit per the manufacturer's instructions.

All-pole power switch - Incorporate an all-pole power switch, with a contact separation of at least 3 mm in each pole, into the electrical installation of the building. If it is needed to open the housing for servicing and/or other activities, use this all-pole switch as the main disconnect device for switching off the voltage to the unit.

Camera grounding - For mounting the camera in potentially damp environments, ensure to ground the system using the ground connection of the power supply connector (see section: Connecting external power supply).

Camera lens - An assembled camera lens in the outdoor housing must comply and be tested in accordance with *UL/IEC60950*. Any output or signal lines from the camera must be SELV or Limited Power Source. For safety reasons the environmental specification of the camera lens assembly must be within the environmental specification of -10 °C (14 °F) to 50 °C (122 °F).

Camera signal - Protect the cable with a primary protector if the camera signal is beyond 140 feet, in accordance with *NEC800 (CEC Section 60)*.

Coax grounding:

- Ground the cable system if connecting an outside cable system to the unit.
- Connect outdoor equipment to the unit's inputs only after this unit has had its grounding plug connected to a grounded outlet or its ground terminal is properly connected to a ground source.
- Disconnect the unit's input connectors from outdoor equipment before disconnecting the grounding plug or grounding terminal.
- Follow proper safety precautions such as grounding for any outdoor device connected to this unit.

U.S.A. models only - *Section 810 of the National Electrical Code, ANSI/NFPA No.70*, provides information regarding proper grounding of the mount and supporting structure, grounding of the coax to a discharge unit, size of grounding conductors, location of discharge unit, connection to grounding electrodes, and requirements for the grounding electrode.



NOTICE!

This device is intended for use in public areas only.

U.S. federal law strictly prohibits surreptitious recording of oral communications.



Your Bosch product was developed and manufactured with high-quality material and components that can be recycled and reused. This symbol means that electronic and electrical appliances, which have reached the end of their working life, must be collected and disposed of separately from household waste material. Separate collecting systems are usually in place for disused electronic and electrical products. Please dispose of these units at an environmentally compatible recycling facility, per *European Directive 2002/96/EC*.

Environmental statement - Bosch has a strong commitment towards the environment. This unit has been designed to respect the environment as much as possible.

Electrostatic-sensitive device - Use proper CMOS/MOS-FET handling precautions to avoid electrostatic discharge.

NOTE: Wear required grounded wrist straps and observe proper ESD safety precautions when handling the electrostatic-sensitive printed circuit boards.

Fuse rating - For security protection of the device, the branch circuit protection must be secured with a maximum fuse rating of 16A. This must be in accordance with *NEC800 (CEC Section 60)*.

Grounding and polarization - This unit may be equipped with a polarized alternating current line plug (a plug with one blade wider than the other blade). This safety feature allows the plug to fit into the power outlet in only one way. If unable to insert the plug fully into the outlet, contact a locally certified electrician to replace the obsolete outlet. Do not defeat the safety purpose of the polarized plug.

Alternately, this unit may be equipped with a 3-pole grounding plug (a plug with a third pin for earth grounding). This safety feature allows the plug to fit into a grounded power outlet only. If unable to insert the plug into the outlet, contact a locally certified electrician to replace the obsolete outlet. Do not defeat the safety purpose of the grounding plug.

Moving - Disconnect the power before moving the unit. Move the unit with care. Excessive force or shock may damage the unit and the hard disk drives.

Outdoor signals - The installation for outdoor signals, especially regarding clearance from power and lightning conductors and transient protection, must be in accordance with *NEC725* and *NEC800 (CEC Rule 16-224 and CEC Section 60)*.

Permanently connected equipment - Incorporate a readily accessible disconnect device in the building installation wiring.

Pluggable equipment - Install the socket outlet near the equipment so it is easily accessible.

PoE - Never supply power via the Ethernet connection (PoE) when power is already supplied via the power connector.

Power disconnect - Units have power supplied whenever the power cord is inserted into the power source. The power cord is the main power disconnect for all units.

Power lines - Do not locate the camera near overhead power lines, power circuits, or electrical lights, nor where it may contact such power lines, circuits, or lights.

SELV

All the input/output ports are Safety Extra Low Voltage (SELV) circuits. SELV circuits should only be connected to other SELV circuits.

Because the ISDN circuits are treated like telephone-network voltage, avoid connecting the SELV circuit to the Telephone Network Voltage (TNV) circuits.

Video loss - Video loss is inherent to digital video recording; therefore, Bosch Security Systems cannot be held liable for any damage that results from missing video information. To minimize the risk of lost digital information, Bosch Security Systems recommends multiple, redundant recording systems, and a procedure to back up all analog and digital information.



NOTICE!

This is a class A product. In a domestic environment this product may cause radio interference, in which case the user may be required to take adequate measures.

FCC & ICES INFORMATION

(U.S.A. and Canadian Models Only, CLASS A)

This device complies with *part 15* of the *FCC Rules*. Operation is subject to the following conditions:

- this device may not cause harmful interference, and
- this device must accept any interference received, including interference that may cause undesired operation.

Note

This equipment has been tested and found to comply with the limits for a Class A digital device, pursuant to Part 15 of the FCC Rules and ICES-003 of Industry Canada. These limits are designed to provide reasonable protection against harmful interference when the equipment is operated in a commercial environment. This equipment generates, uses, and radiates radio frequency energy and, if not installed and used in accordance with the instruction manual, may cause harmful interference to radio communications. Operation of this equipment in a residential area is likely to cause harmful interference, in which case the user will be required to correct the interference at his expense.

Intentional or unintentional modifications, not expressly approved by the party responsible for compliance, shall not be made. Any such modifications could void the user's authority to operate the equipment. If necessary, the user should consult the dealer or an experienced radio/television technician for corrective action.

The user may find the following booklet, prepared by the Federal Communications Commission, helpful: *How to Identify and Resolve Radio-TV Interference Problems*. This booklet is available from the U.S. Government Printing Office, Washington, DC 20402, Stock No. 004-000-00345-4.

INFORMATIONS FCC ET ICES (commercial applications)

(modèles utilisés aux États-Unis et au Canada uniquement, CLASSE A)

Ce produit est conforme aux normes FCC partie 15. La mise en service est soumise aux deux conditions suivantes:

- cet appareil ne peut pas provoquer d'interférence nuisible et
- cet appareil doit pouvoir tolérer toutes les interférences auxquelles il est soumis, y compris les interférences qui pourraient influencer sur son bon fonctionnement.

AVERTISSEMENT: Suite à différents tests, cet appareil s'est révélé conforme aux exigences imposées aux appareils numériques de Classe A en vertu de la section 15 du règlement de la Commission fédérale des communications des États-Unis (FCC). Ces contraintes sont destinées à fournir une protection raisonnable contre les interférences nuisibles quand l'appareil est utilisé dans une installation commerciale. Cet appareil génère, utilise et émet de l'énergie de fréquence radio, et peut, en cas d'installation ou d'utilisation non conforme aux instructions, générer des interférences nuisibles aux communications radio. L'utilisation de ce produit dans une zone résidentielle peut provoquer des interférences nuisibles. Le cas échéant, l'utilisateur devra remédier à ces interférences à ses propres frais.

Au besoin, l'utilisateur consultera son revendeur ou un technicien qualifié en radio/télévision, qui procédera à une opération corrective. La brochure suivante, publiée par la Commission fédérale des communications (FCC), peut s'avérer utile : « How to Identify and Resolve Radio-TV Interference Problems » (Comment identifier et résoudre les problèmes d'interférences de radio et de télévision). Cette brochure est disponible auprès du U.S. Government Printing Office, Washington, DC 20402, États-Unis, sous la référence n° 004-000-00345-4.

AVERTISSEMENT: Ce produit est un appareil de Classe A. Son utilisation dans une zone résidentielle risque de provoquer des interférences. Le cas échéant, l'utilisateur devra prendre les mesures nécessaires pour y remédier.

Disclaimer

Underwriter Laboratories Inc. ("UL") has not tested the performance or reliability of the security or signaling aspects of this product. UL has only tested fire, shock and/or casualty hazards as outlined in UL's *Standard(s) for Safety for Information Technology Equipment, UL 60950-1*. UL Certification does not cover the performance or reliability of the security or signaling aspects of this product.

UL MAKES NO REPRESENTATIONS, WARRANTIES, OR CERTIFICATIONS WHATSOEVER REGARDING THE PERFORMANCE OR RELIABILITY OF ANY SECURITY OR SIGNALING-RELATED FUNCTIONS OF THIS PRODUCT.

Copyright

This user guide is the intellectual property of Bosch Security Systems, Inc. and is protected by copyright.

All rights reserved.

Trademarks

All hardware and software product names used in this document are likely to be registered trademarks and must be treated accordingly.

**NOTICE!**

This user guide has been compiled with great care and the information it contains has been thoroughly verified. The text was complete and correct at the time of printing. The ongoing development of the products may mean that the content of the user guide can change without notice. Bosch Security Systems accepts no liability for damage resulting directly or indirectly from faults, incompleteness or discrepancies between the user guide and the product described.

1.5 Customer Support and Service

If this unit needs service, contact the nearest Bosch Security Systems Service Center for authorization to return and shipping instructions.

Service Centers

USA

Telephone: 800-366-2283 or 585-340-4162

Fax: 800-366-1329

Email: cctv.repair@us.bosch.com

Customer Service

Telephone: 888-289-0096

Fax: 585-223-9180

Email: security.sales@us.bosch.com

Technical Support

Telephone: 800-326-1450

Fax: 585-223-3508 or 717-735-6560

Email: technical.support@us.bosch.com

Repair Center

Telephone: 585-421-4220

Fax: 585-223-9180 or 717-735-6561

Email: security.repair@us.bosch.com

Canada

Telephone: 514-738-2434

Fax: 514-738-8480

Europe, Middle East & Asia Pacific Region

Telephone: 44 (0) 1495 274558

Fax: 44 (0) 1495 274280

Email: rmahelpdesk@solectron.com

More information

For additional information, please contact your Bosch Security Systems representative or visit our web site at www.boschsecurity.com

2 Installing the Pendant Arm Wall, Corner, and Mast (Pole) Mounts

2.1 Unpacking

This equipment should be unpacked and handled with care. If an item appears to have been damaged in shipment, notify the shipper immediately.

Verify that all the parts listed in the Parts List below are included. If any items are missing, notify your Bosch Security Systems Sales or Customer Service Representative. See *Section 1.5 Customer Support and Service, page 12* for contact information.

The original packing carton is the safest container in which to transport the unit and must be used if returning the unit for service. Save it for possible future use.

2.1.1 Parts List

The following table lists the parts included with the Pendant Arm Wall, Corner, or Mast mount packages.

Mount Kit Options	Part Numbers
Pendant Arm (Only)	F01U010586
Pendant Arm with Mounting Plate (24 V VG4 models only, no power supply box)	VG4-A-ARMPLATE
Pendant Housing (with COMMS and CPU modules installed): – Analog VG4 AutoDome – IP-enabled AutoDome	VG4-XXX-O or -S VG4-XXX-E
Optional Housing Modules – Environmental Shield – Pressurized Environmental Housing	VG4-MHSG-EX VG4-MHSG-NX
Pendant Arm with one of the following Power Supply Boxes:	
– Power Box without transformer (24 VAC)	VG4-A-PA0
– Power Box with 120 VAC transformer or with 230 VAC transformer	VG4-A-PA1 VG4-A-PA2
– Power Box without transformer with Fiber Optic Module (24 VAC)	VG4-A-PA0F
– Power Box with 120 VAC transformer and Fiber Optic Module or with 230 VAC transformer and Fiber Optic Module	VG4-A-PA1F VG4-A-PA2F
Trim Skirt Power Supply Box	F01U005225
Corner Mount Kit	
– Corner Mount Plate	VG4-A-9542
Mast (Pole) Mount Kit	
– Mast Mount Plate	VG4-A-9541
Bubble	
– Clear Bubble with white trim ring, or – Tinted Bubble with white trim ring – Optional white bubble support ring for Pressurized Environmental Housing	VG4-SBUB-PCL VG4-SBUB-PTI

The following figures depict the parts (some optional) for a pendant arm wall, corner, or mast mount.

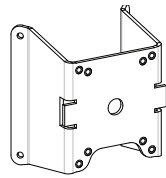

Corner Plate (optional)

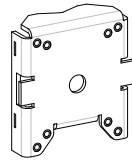

Mast Plate (optional)

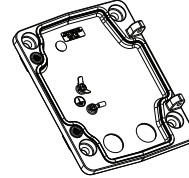

Mounting Plate (optional)

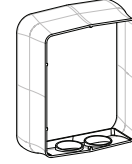

Trim Skirt (optional)

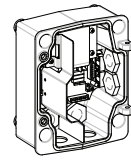

Power Supply

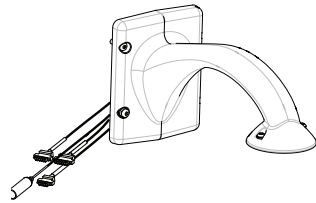

Pendant Arm



Pendant Housing



Environmental Shield (optional)



Pressurized Environmental Housing (optional)

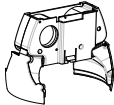

Heater Module (optional)



COMMS Module

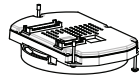

CPU Module



Camera Module



Dome Bubble



Bubble Support Ring for Pressurized Environmental Housing (optional)

2.1.2

Description

Chapter 2 details how to install an AutoDome Pendant Arm to a wall, a corner, or to a mast (pole). Any variations to the installation procedures are noted.

See Chapter 3 for a Roof (Parapet) or Pipe mount installation or Chapter 4 for an In-Ceiling mount installation.

2.1.3

Tools Required

- 5 mm Allen wrench (supplied)
- Small, straight-blade screwdriver - 2.5 mm (0.1 in.)
- No. 2 Phillips screwdriver
- Socket wrench and 9/16-in. socket
- Banding tool (Bosch P/N TC9311PM3T) - if installing a mast (pole) mount
- 3/4 in. (20-mm) NPS right angle conduit connector - if installing a mast (pole) mount with a VG4-ARMPLATE
- Pin-in Torx tool (supplied) or a T25 pin-in Torx driver (for Pressurized Environmental Housing)
- Dial-indicator Torque Screwdriver (for Pressurized Environmental Housing)

2.2

Pre-installation Checklist

1. Determine the location and distance for the Power Supply Box based on its voltage and current consumption.
You may choose to route the main power supply through an intermediate VG4 power supply box (VG4-PSU1 or VG4-PSU2) before connecting the power to the pendant arm power supply box (VG4-PA0). See *Section 5 Cable and Wire Standards, page 85*, for wiring information and distances.
2. Use only UL listed liquid tight strain reliefs for conduits to the Power Supply Box to ensure that water cannot enter the box. You must use water tight conduits and fittings to meet NEMA 4 standards.



WARNING!

Power and I/O cabling must be routed separately inside different permanently earthed metal conduits.

3. Route all rough wiring including: power, control, video coax, alarms I/O, relay I/O, and fiber optic cabling. See *Section 5 Cable and Wire Standards, page 85*, for video and control protocol methods.



WARNING!

Install external interconnecting cables in accordance to NEC, ANSI/NFPA70 (for US application) and Canadian Electrical Code, Part I, CSA C22.1 (for CAN application) and in accordance to local country codes for all other countries.

Branch circuit protection incorporating a 20 A, 2-pole Listed Circuit Breaker or Branch Rated Fuses are required as part of the building installation. A readily accessible 2-pole disconnect device with a contact separation of at least 3 mm must be incorporated.

4. Choose the appropriate AutoDome model (indoor or outdoor) for the environment in which it will be used.
5. If this AutoDome installation utilizes the AutoTracker feature, refer to *Section A Installation Notes for AutoTracker, page 101*, before mounting the AutoDome.

- Choose the appropriate mounting kit to use, depending on the location of the AutoDome, either wall mount, corner mount, or mast (pole) mount.

If the kit contains a Power Supply Box, refer to *Section 2.3 Mount Power Supply Box, page 16*.

If you are using the Mounting Plate with a 24 V VG4 AutoDome, refer to *Section 2.8 Installing the VG4-A-ARMPLATE, page 27*.



CAUTION!

Select a rigid mounting location to prevent excessive vibration to the AutoDome camera.

2.3

Mount Power Supply Box

Before mounting the Power Supply Box decide if you should wire the box through the holes in the bottom or back of the box. If wiring the box through the back, move the two (2) seal plugs to the bottom through the holes before mounting.



NOTICE! Use 3/4-inch (20-mm) NPS fittings for the holes on the bottom and back of the box. Use 1/2-inch (15-mm) NPS fittings for the side holes.

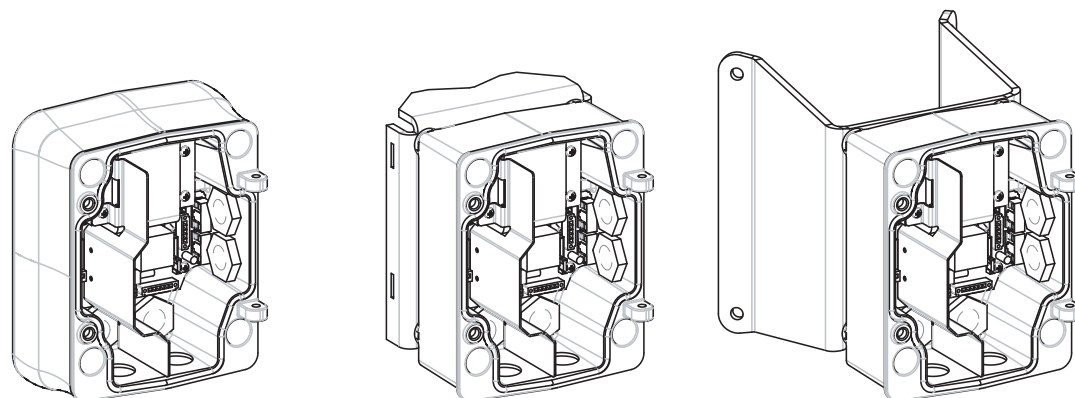

Figure 2.1 Power Supply Wall, Mast (Pole), and Corner Mounts

- Use the wall mount template supplied in the packaging box to locate the four mounting holes for the Power Supply Box.
- Drill four (4) holes for the mounting anchors. If installing outdoors, apply a weatherproof sealant around each hole at the mounting surface.



WARNING!

A stud diameter of 6.4 mm (1/4 inch) to 8 mm (5/16 inch) able to withstand a 120 kg (265 lb) pull-out force is recommended. The mounting material must be able to withstand this pull out force. For example, 19-mm (3/4-inch) minimum for plywood.

- Place the Power Supply Box into the optional Trim Skirt.

4. Secure the Power Supply Box to the mounting surface.
 - For a Wall installation: Use four (4) corrosion-resistant, stainless steel studs (not supplied). Then proceed to Step 5 below.
 - For a Corner installation: Secure the Corner Plate to the wall corner using four (4) studs (not included). Then proceed to Step 5 below.
 - For a Mast or a pole installation: The metal straps included with the Mast mount accommodate a pole with a diameter of 100–380 mm (4–15 in.). You must use a banding tool (sold separately) for a mast or pole installation. Follow the instructions provided with the banding tool to securely mount the Mast Plate to the pole.
Contact your Bosch Sales Representative to order Banding Tool P/N TC9311PM3T.
5. Secure the Power Supply Box to the Corner Plate or Mast Plate using the four (4) 3/8 x 1-3/4-inch bolts and split lock washers (supplied).
6. Attach 3/4-inch (20-mm) NPS watertight pipe fittings (not supplied) to the bottom or back holes of the Power Supply Box through which you will run the power, video, and control data wires.

2.4 Route Wires and Attach Connectors

Power wires must be routed to the left (front) side of the Power Supply Box through a separate conduit. All video, control, and alarm wires must be routed through a second conduit to the right side of the box.

If you plan to route the power through an intermediate power supply box, refer to *Section 2.5 Route Power through Intermediate Power Supply Box, page 21.*



WARNING!

External interconnecting cables are to be installed in accordance to NEC, ANSI/NFPA70 (for US application) and Canadian Electrical Code, Part I, CSA C22.1 (for CAN application) and in accordance to local country codes for all other countries.

Branch circuit protection incorporating a 20 A, 2-pole Listed Circuit Breaker or Branch Rated Fuses are required as part of the building installation. A readily accessible 2-pole disconnect device with a contact separation of at least 3 mm must be incorporated.

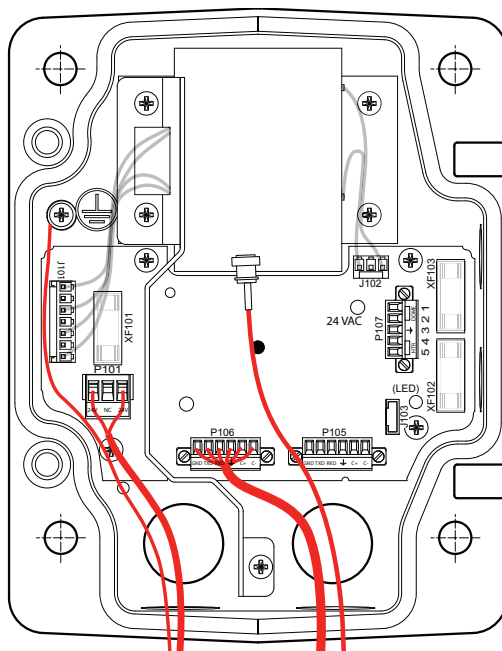

Figure 2.2 Pendant Arm Power Supply Box

1. Route all video, control, and alarm wires through the conduit fitting on the right side of the power box. See *Section 5 Cable and Wire Standards, page 85*, for coax, UTP, and fiber optic specifications and distances.
2. Route the high voltage 115/230 VAC lines through the conduit fitting on the left side of the box. The Power Supply Box with a transformer comes with a barrier that separates the high voltage side on the left, from the low voltage 24 VAC side on the right.
3. Cut and trim all wires with sufficient slack to reach their connector terminals in the box, but not so long as to be pinched by or to obstruct closing the Pendant Arm. See *Figure 2.2, Page 17*, above, for the connector locations.
4. Attach the supplied 3-pin Power Plug to the incoming power wires. See connector P101 in *Table 2.1, Page 21*, for wire connections.
5. Attach the supplied 6-pin Control Data I/O Plug to the incoming control wires. See connector P106 in *Table 2.1, Page 21*, for wire connections. This step is not required with Fiber Optic models, since control passes through the fiber optic cable.



NOTICE! If “daisy chaining” a series of AutoDomes, a terminating resistor is required in the last dome of the series. The Bosch Power Supply Box is supplied with a 100 Ω terminating resistor located between the Biphase terminals C- and C+ (pins 1 and 2) of the P106 control connector. Remove the resistor from all but the last AutoDome power box. The maximum number of AutoDomes that can be daisy chained is four (4). If using the RS485 protocol for control, the terminating resistor must be moved from the Biphase C+ and C- (pins 1 and 2) terminals to the RXD- and TXD+ terminals (pins 4 and 5) of the P106 control connector of the last AutoDome power box.

6. Attach a BNC connector to the incoming video coax cable. If using UTP for video or installing an Ethernet model, attach an RJ45 plug to the incoming UTP cable. If installing a Fiber Optic model, attach an ST fiber plug to the optic fiber cable. See *Section 5 Cable and Wire Standards, page 85*, for the different methods of transmitting video and control protocols, and wire specifications.

- If you are connecting alarm inputs and outputs, attach the supplied 4- and 6-pin Alarm Connectors with flying lead wires to the appropriate incoming alarm wires.

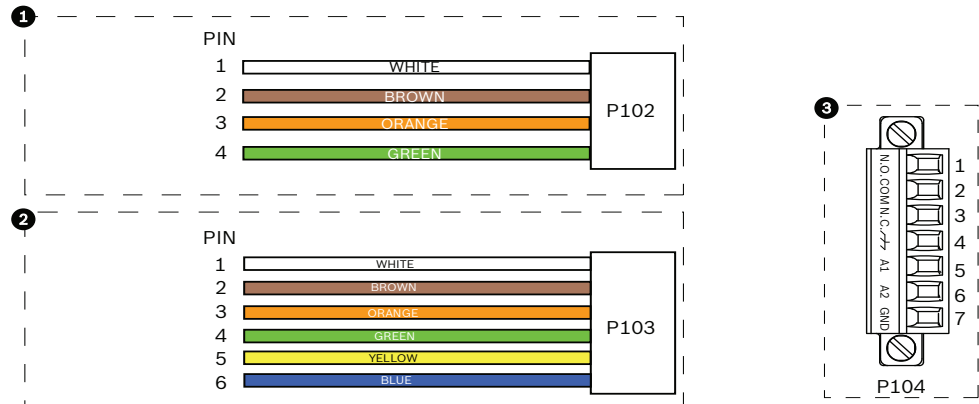

Figure 2.3 Alarm and relay connectors

1	4-pin Alarm Connector (P102)	2	6-pin Alarm In Connector (P103)	3	7-pin Relay Connector (P104)
Pin	Description	Pin	Description	Pin	Description
1	Alarm Out 1	1	Alarm In 3	1	Normally Open
2	Alarm Out 2	2	Alarm In 4	2	COM
3	Alarm Out 3*	3	Alarm In 5	3	Normally Closed
4	Alarm Ground	4	Alarm In 6	4	Earth Ground
		5	Alarm In 7	5	Analog Alarm 1
		6	Alarm Ground	6	Analog Alarm 2
				7	Ground

* The Alarm Out 3 (on the P102 connector) is the dedicated low pressure alarm for VG4 100 Series AutoDome cameras.

- If you are connecting supervised alarms and relays, attach the supplied 7-pin Relay Connector to the appropriate incoming wires. See *Figure 2.3, Page 19*, above, for the wire connections. See *Section 6 Alarms and Relay Connections, page 96* for more details about wiring alarms and relays.

2.4.1 Power Supply Box Connections

The following figure is a detailed illustration of the Pendant Arm Power Supply Box, which includes the fuse specifications.

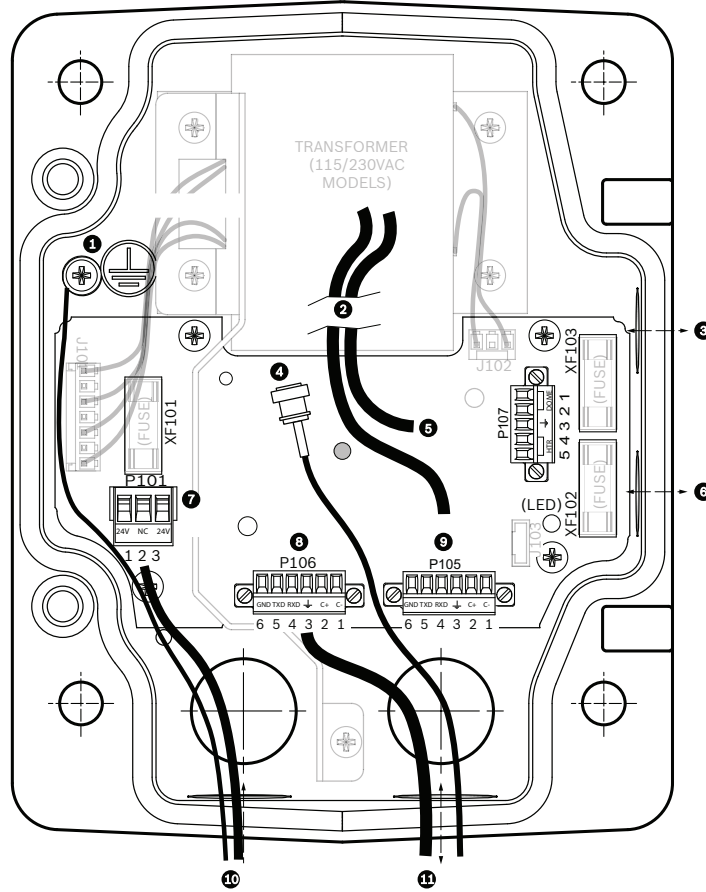

Figure 2.4 Pendant arm power supply box

1	Ground Screw	7	P101 Connector; Power In
2	From Harness	8	P106 Connector; Control In/Out
3	In/Out; 1/2 in. (15 mm) NPS Fitting	9	P105 Connector; Control to Dome
4	Video	10	Power In; 3/4 in. (20 mm) NPS Fitting
5	24 VAC to Dome	11	Control Data and Video In/Out; 3/4 in. (20 mm) NPS Fitting
6	In/Out; 1/2 in. (15 mm) NPS Fitting		



WARNING!

Fuse replacement by qualified service personnel only. Replace with same type fuse.

Fuse Specifications			
Volts	XF101 Mains	XF102 Camera	XF103 Heater
24 V	T 5.0 A	T 2.0 A	T 3.15 A
115 V	T 1.6 A	T 2.0 A	T 3.15 A
230 V	T 0.8A	T 2.0 A	T 3.15 A

The following table lists the Power Supply Box connectors:

No.	Connector	Pin 1	Pin 2	Pin 3	Pin 4	Pin 5	Pin 6
	Ground	Grounding Screw					
P101	115/230 VAC or 24 VAC Power In	Line	NC	Neutral			
P105	Control to Dome (Arm Harness)	C- (Biphase)	C+ (Biphase)	Earth Ground	RXD (+) (RS-232/485)	TXD (-) (RS-232/485)	Signal Ground
P106	Control In/Out	C- (Biphase)	C+ (Biphase)	Earth Ground	RXD (+) (RS-232/485)	TXD (-) (RS-232/485)	Signal Ground
P107	24 VAC Power (Arm Harness)	Dome 24 VAC	Dome 24 VAC	Earth Ground	Heater (24 VAC)	Heater (24 VAC)	

Table 2.1 Power Supply Box Connections

2.5

Route Power through Intermediate Power Supply Box

You may route the main power supply through a VG4-PSU1 (120 V transformer) or through a VG4-PSU2 (230 V transformer) Power Supply Box before connecting the power to a VG4-PA0 (24 V, no transformer) Power Supply Box. The main issue with this configuration is that the 5-pin power out connector from the VG4-PSU1 or VG4-PSU2 does not match to the 3-pin power input of the VG4-PA0 power supply. The illustration below depicts:

- A VG4-PSU1/VG4-PSU2 Power Supply Box.
- The main power supply connected to the P101 connector and to the grounding screw.
- The 24 VAC power out wire connected to the P107 heater power connectors.

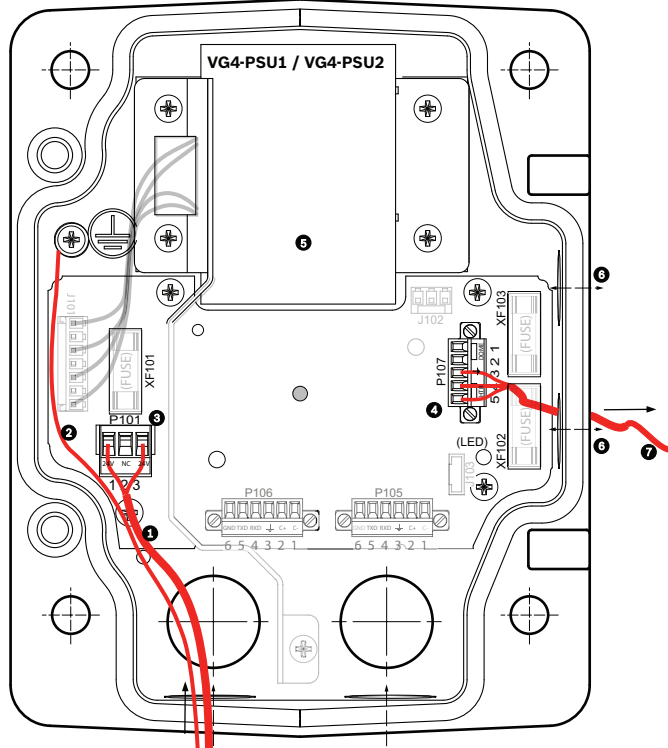

Figure 2.5 VG4-PSU1/VG4-PSU2 Power Supply Box

1	120/230 VAC Power In	5	Transformer
2	Ground Wire	6	In/Out Conduit (1/2 in. [15 mm] NPS Fitting)
3	P101 Connector	7	24 VAC Power Out to VG4-PA0
4	P107 Connector		

To properly wire the incoming high voltage and the outgoing low voltage lines, refer to this table:

No.	Connector	Pin 1	Pin 2	Pin 3	Pin 4	Pin 5	Pin 6
	Ground	Grounding Screw					
P101	115/230 VAC Power In	Line	NC	Neutral			
P107	24 VAC Power Out			Earth Ground	Heater (24 VAC)	Heater (24 VAC)	

Table 2.2 VG4-PSU1/VG4-PSU2 Power Supply Box Connections

1. Route the high voltage 115/230 VAC lines through the conduit fitting on the left side of the box. The Power Supply Box with a transformer comes with a barrier that separates the high voltage side on the left, from the low voltage 24 VAC side on the right.
2. Cut and trim the high voltage 115/230 VAC power and ground wires with sufficient slack to reach their connector terminal in the box, but not so long as to be pinched by or to obstruct closing the cover door.
3. Attach the supplied 3-pin power plug to the incoming high voltage power wires in the box. Refer to connector P101 in *Table 2.2, Page 22* and to the image below for an illustration of these connections:

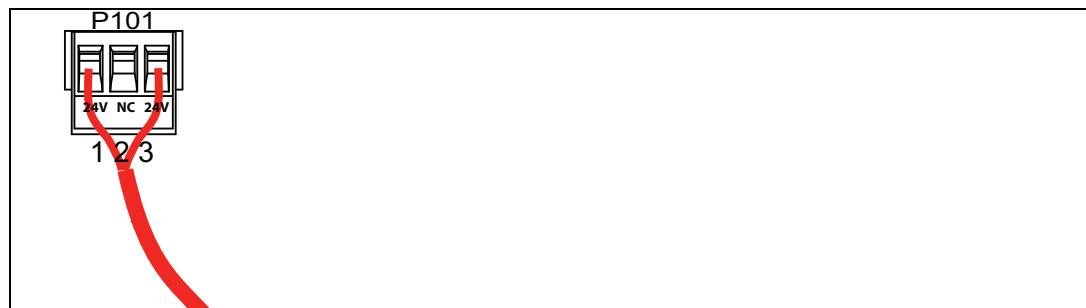

Figure 2.6 Incoming 115/230 VAC power supply

4. Attach the ground wire to the grounding screw.
5. Connect three wires to the P107 Power Out connector to route the 24 VAC power supply to the VG4-PA0 Power Supply Box.
 - a. Connect the first wire to pin 5 (HN: Heater Neutral) connector.
 - b. Connect the second wire to pin 4 (HL: Heater Line) connector.
 - c. Connect the third wire to pin 3 (Earth Ground) connector.

Refer to connector P107 in *Table 2.2* and to the image below for an illustration of these connections:

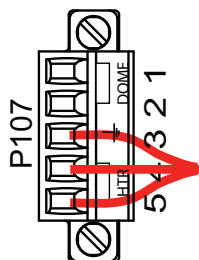

Figure 2.7 Outgoing 24 VAC power supply



WARNING!

Ensure that you connect the outgoing power supply wires to the P107 heater connectors (HN and HL). The heater power (XF103) fuse can handle a higher amperage (3.15 A) than the camera power (XF102) fuse (2.0 A).

6. Route the 24 VAC outgoing power supply wires into the VG4-PA0 power supply box through the conduit fitting on the left side of the box.
7. Cut and trim the 24 VAC power and ground wires with sufficient slack to reach their connector terminal in the box, but not so long as to be pinched by or to obstruct closing the cover door.
8. Attach the supplied 3-pin power plug to the incoming 24 VAC power wires in the box, as illustrated below.

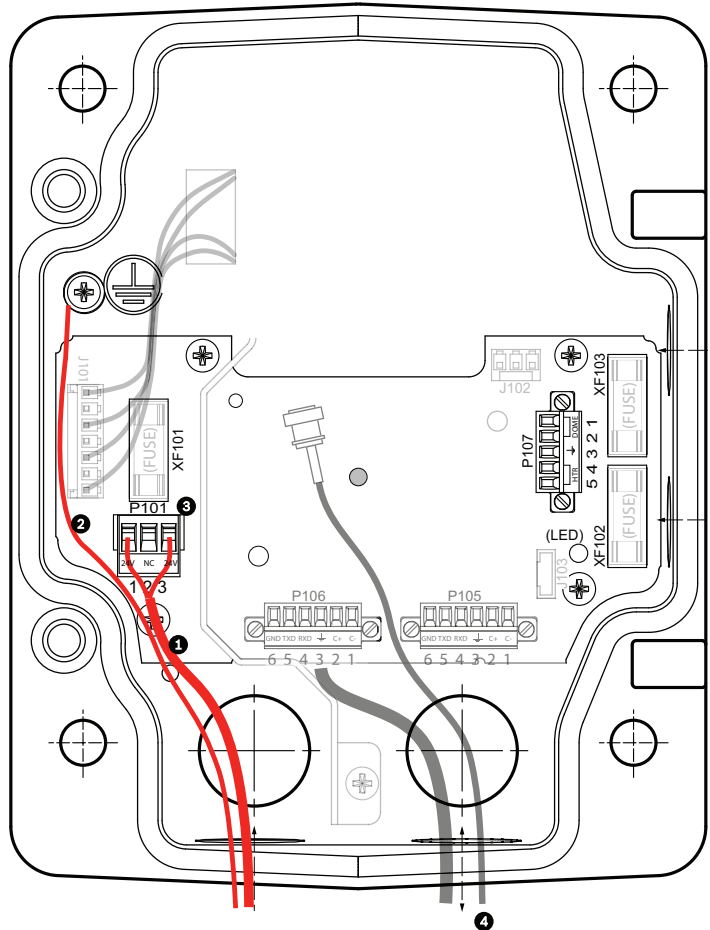

Figure 2.8 VG4-PA0 Power Supply Box

1	Incoming 24 VAC Power Supply Wires (from VG4-PSU1/VG4-PSU2 power supply box)
2	Ground Wire
3	P101 Connector
4	Control Data and Video In/Out Wires

9. Follow the instructions in *Section 2.6 Attach Pendant Arm to Power Supply Box, page 24*, to continue the installation.

2.6 Attach Pendant Arm to Power Supply Box

The bottom hinge pin of the Pendant Arm is provided with a Hinge Pin Stop to hold the hinge open while attaching the arm to the Power Supply Box.

1. Compress the bottom hinge pin by pushing the pin lever downward and rotating it behind the Hinge Pin Stop.

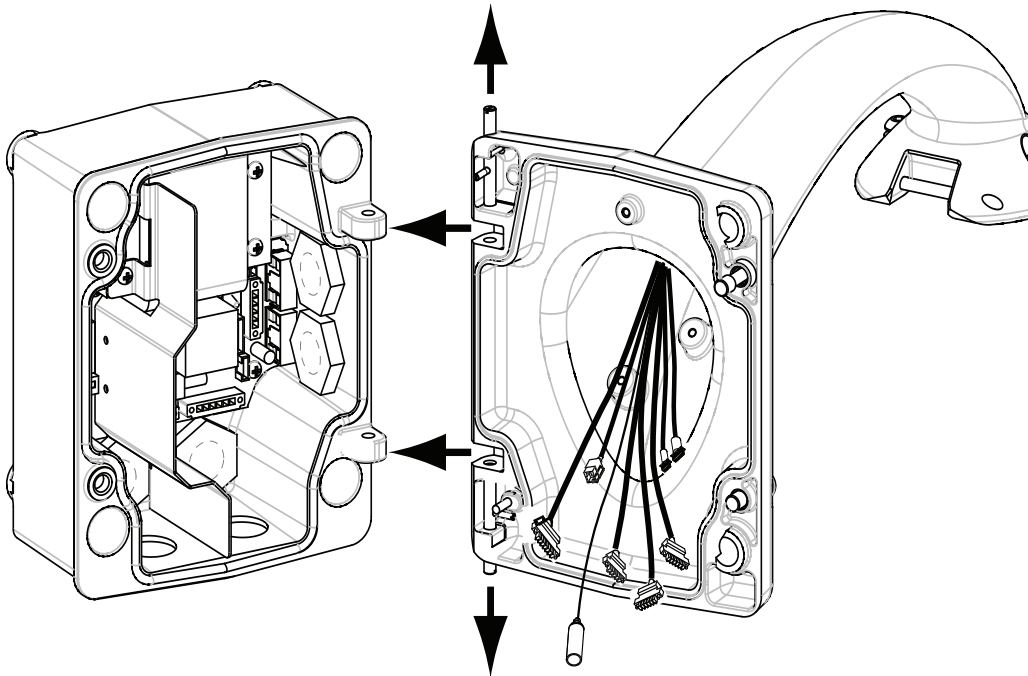

Figure 2.9 Pendant Arm to Power Box Hinge Alignment

2. Open the top hinge by pushing its pin lever up and holding it.



NOTICE! Both Hinge Pins must be fully compressed to open (unlock) the hinges of the Pendant Arm and before proceeding to the next step.

3. While continuing to hold the top hinge pin open and align the top and bottom hinges of the Pendant Arm to their mating points on the Power Supply Box. See *Figure 2.9*, above, for an illustration.
4. Once you have the hinges aligned, release the top hinge pin to engage its mating hinge on the power box. Then release the bottom hinge pin from the Hinge Pin Stop to lock the Pendant Arm to the Power Supply Box.



WARNING!

Serious injury or death can occur if the hinge pins of the Pendant Arm are not fully engaged (locked) to the Power Supply Box. Exercise caution before releasing the Pendant Arm.

2.7 Make Connections in Power Supply Box

Refer to *Table 2.2, Page 22* to locate the various connectors in the power supply box and make the following connections detailed below.

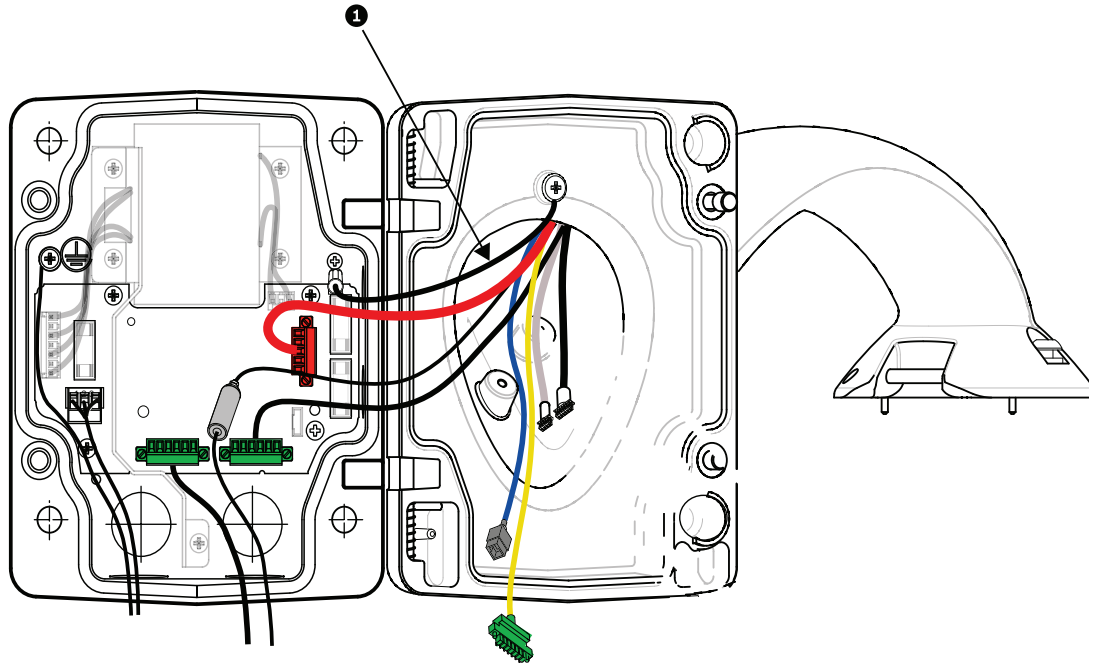
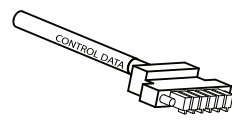
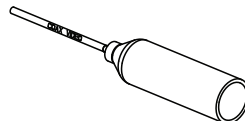

Figure 2.10 Pendant Arm connections to Power Supply Box

1. Attach the earth ground wire (item 1 in the illustration above) to the grounding screw on the left side of the power box.
2. Connect the 6-pin Control In/Out Plug, installed previously, to its mating connector P106 in the power box. If this product is a Fiber Optic model this step is not required, since all control data is sent through the fiber cable.
3. Connect the 6-pin Control to Dome Plug from the Pendant Connector Harness to its mating connector P105 in the power box. (For Fiber Optic model connect to the P106 connector.)



Control Data



Coax Video

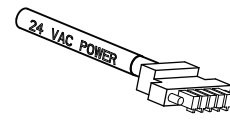

24 VAC Power

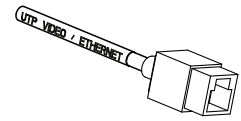

UTP Video/Ethernet



Alarm Inputs



Alarm Outputs



Relays

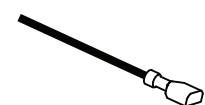

Grounding Strap



WARNING!

Do not connect the RJ45 connector unless using UTP video or Ethernet.

4. Connect the 5-pin, 24 VAC to Dome Plug from the Pendant Connector Harness to its corresponding color mating connector P107 on the right side of the box.

5. Connect the incoming video coax cable to the BNC connector from the Pendant Connector Harness and slide its plastic cover over the connector.
6. To connect alarm inputs and relay outputs, connect the 4-pin Alarms Out, the 6-pin Alarms In and the 7-pin Relay connectors from the Pendant Connector Harness to their mating connectors, installed previously, to the incoming alarm wires.
7. Connect the 3-pin Power In Plug, installed previously, to its mating connector P101 on the left side of the box.
8. If installing a Fiber Optic model attach the incoming ST fiber plug, installed previously, to its mating connector on the Fiber Optic Module in the power supply box. Then attach the video BNC plug to its mating connector from the Pendant Connector Harness. See *Section 5 Cable and Wire Standards, page 85* for fiber optic specifications.

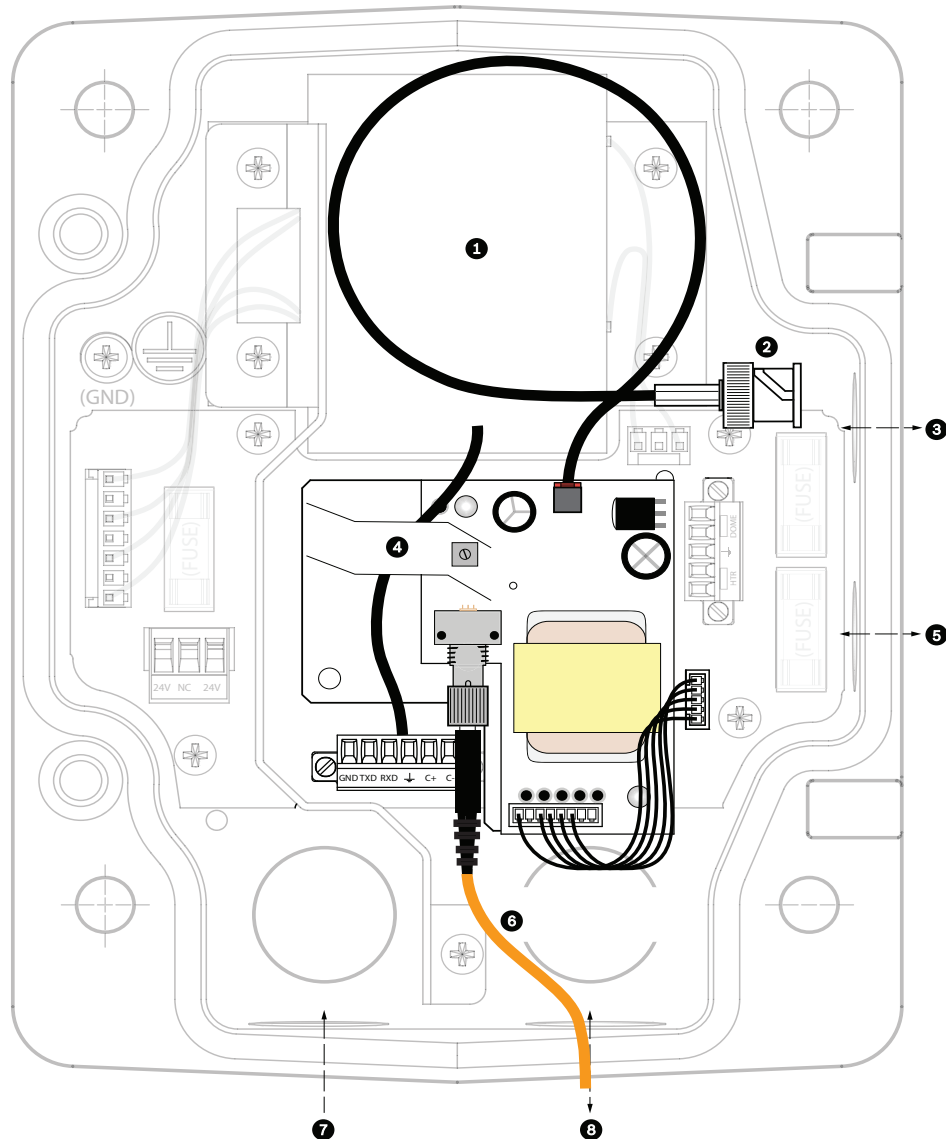

Figure 2.11 Optional Fiber Optic Module

1	Transformer	5	In/Out
2	BNC to Dome	6	ST Connector (Fiber)
3	In/Out	7	Power In
4	From Arm Harness	8	Data In/Out

9. If using UTP for video or Ethernet, connect the incoming RJ45 video connector, installed previously, to its mating connector from the Pendant Connector Harness. See *Section 5 Cable and Wire Standards, page 85* for connections and specifications.
10. Attach the grounding strap of the Pendant Arm to the Power Supply Box. See *Figure 2.10, Page 25*.
11. After making the harness connections to the Power Supply Box, rotate the Pendant Arm to close and seal the Power Supply Box and tighten the two (2) captive screws to 10-12 N-m (90-105 in.-lbs).
12. Refer to *Section 2.9 Assemble Pendant in Packing Box, page 31*, to continue the VG4 AutoDome Installation procedure.



NOTICE! After all wiring is complete, close the cover door and tighten the two (2) captive screws on the cover door to 10-12 N-m (90-105 in.-lbs) to ensure the Power Supply Box is watertight.

2.8

Installing the VG4-A-ARMPLATE

This section provides instructions to install a wall, corner, or mast mount with the VG4-A-ARMPLATE Mounting Plate instead of a Power Supply Box.



CAUTION!

You must route the main power supply through a 120/230 VAC transformer (VG4-PSU1 or VG4-PSU2 power supply box) before connecting the power to a 24 VAC AutoDome.



WARNING!

A stud diameter of 6.4 mm (1/4 inch) to 8 mm (5/16 inch) able to withstand a 120 kg (265 lb) pull-out force is recommended. The mounting material must be able to withstand this pull out force. For example, 19-mm (3/4-inch) minimum for plywood.

1. **For a Corner installation:**

- a. Secure the Corner Plate to the wall corner using four (4) studs (not included).
- b. Secure the Mounting Plate to the Corner Plate using the four (4) 3/8 x 1-3/4-inch bolts and split lock washers (supplied).

2. **For a Mast or pole installation:**

The metal straps included with the Mast mount accommodate a pole with a diameter of 100–380 mm (4–15 in.). You must use a banding tool (sold separately) for a mast or pole installation. In addition, you must obtain a 3/4 in. (20-mm) right angle conduit connector through which you route the wires that connect to the pendent arm.

- a. Follow the instructions provided with the banding tool to securely mount the Mast Plate to the pole. Contact your Bosch Sales Representative to order Banding Tool P/N TC9311PM3T.
- b. Secure the Mounting Plate to the Mast Plate using the four (4) 3/8 x 1-3/4-inch bolts and split lock washers (supplied).
- c. Remove one of the rubber gaskets from the Mounting Plate.

- d. Once the Mounting Plate (item 1, below) is attached to the Mast Plate (item 2), connect the right angle conduit (item 3) to the Mounting Plate through the empty conduit hole as shown below:

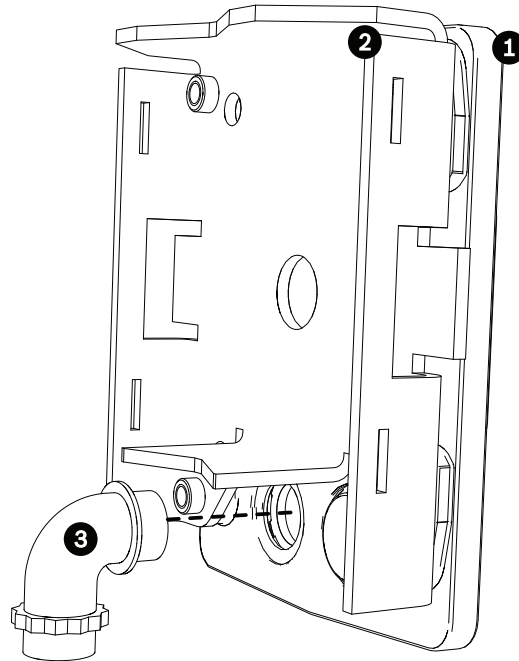

3. Ensure that the mounting plate is secure.

2.8.1

Attach the Pendant Arm to the Mounting Plate

The bottom hinge pin of the Pendant Arm is provided with a Hinge Pin Stop to hold the hinge open while attaching the arm to the Mounting Plate.

1. Compress the bottom hinge pin by pushing the pin lever downward and rotating it behind the Hinge Pin Stop.

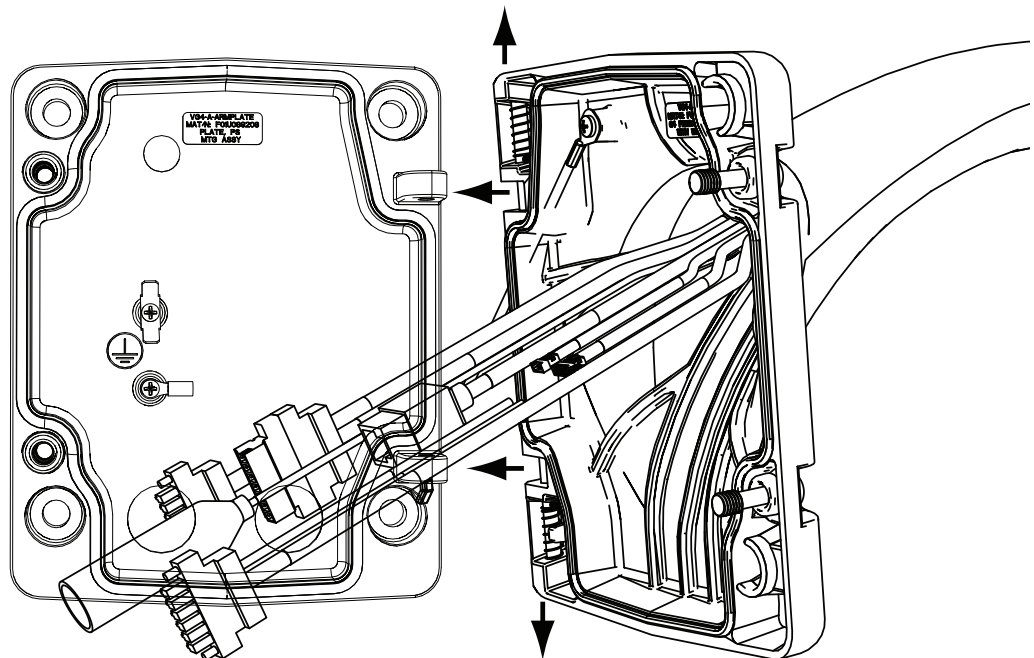

Figure 2.12 Connect Pendant Arm to Mounting Plate

2. Open the top hinge by pushing its pin lever up and holding it.

Note: Both Hinge Pins must be fully compressed to open (unlock) the hinges of the Pendant Arm and before proceeding to the next step.
3. While continuing to hold the top hinge pin open, align the top and bottom hinges of the Pendant Arm to their mating points on the Mounting Plate. See *Figure 2.12*, above, for an illustration.
4. Once you have the hinges aligned, release the top hinge pin to engage its mating hinge on the Mounting Plate. Then release the bottom hinge pin from the Hinge Pin Stop to lock the Pendant Arm to the Mounting Plate.

2.8.2

Route and Connect Wires to a Power Supply Box

The illustration below depicts the power and control cables connected to the Pendant Arm:

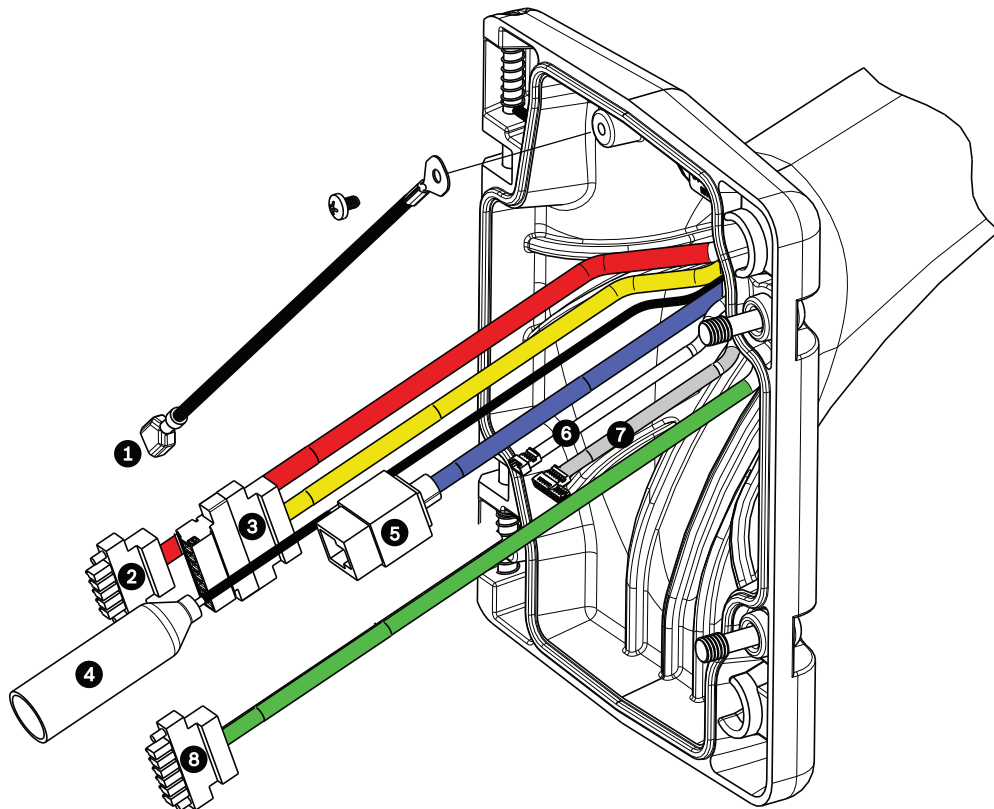

Figure 2.13 Pendant Arm Cables

Cable	Cable	Cable	Cable
1	Grounding Strap (black)	5	UTP Video/Ethernet (blue)
2	24 VAC Power (red)	6	Alarm Outputs (white)
3	Relay Contacts (yellow)	7	Alarm Inputs (gray)
4	Coax Video (black)	8	Serial Communications (green)

1. Route all incoming wires through one of the conduits at the bottom of the Mounting Plate. For a mast mount, route all wires through the right-angle conduit.
2. Attach the water-tight plug to the other conduit.
3. Attach the grounding spade terminal (item 1, below) to one of the spade terminals inside the Mounting Plate.

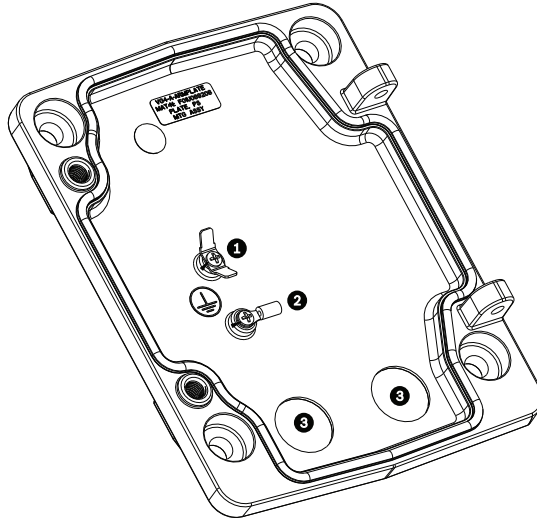
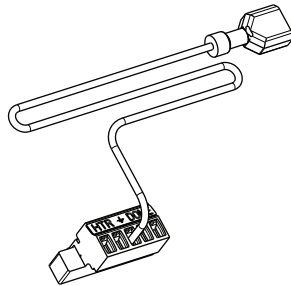

Figure 2.14 Mounting Plate - Inside Detail

Ref.	Description
1	Grounding lug with two spade terminals
2	Earth ground lug with crimp ring terminal
3	Wire input conduit holes

4. Connect the incoming 24 VAC power wires to the 5-pin, 24 VAC Power In mating connector (supplied with the Mounting Plate kit) for the Dome and for the Heater.



5. Attach the grounding spade from the 5-pin mating connector (item 1, *Figure 2.14*) to the other spade terminal inside the mounting plate.
6. Attach the 5-pin Power In mating connector to the 24 VAC Power cable (cable 2) connected to the pendant.
7. Remove the mating connector from the Relay Contacts cable (cable 3).
8. Connect the incoming relay contact wires to the mating connector. Then, reattach the mating connector to the Relay Contacts cable.
9. Connect the incoming video coax cable to the BNC connector (cable 4) and slide its plastic cover over the connector.
10. If using UTP for video or Ethernet, connect the incoming RJ45 video connector, installed previously, to the UTP Video/Ethernet cable (cable 5). Refer to *Section 5 Cable and Wire Standards*, page 85, for detailed wire and connection information.
11. Connect the outgoing alarm wires to the flying leads coming from the 4-pin Alarm Outputs cable (cable 6).

12. Connect the incoming alarms wires to the flying leads coming from the 6-pin Alarm Inputs cable (cable 7).
13. Connect the incoming serial communication wires to the 6-pin mating connector supplied with the VG4-A-ARMPLATE kit. Ensure that the 100 Ω resistor remains connected to the Biphase C- and the Biphase C+ terminals. Remove the resistor only in the following cases:
 - If the AutoDome is not the last AutoDome in a daisy chain.
 - If the Biphase C- and the Biphase C+ terminals receive a line input audio signal.Refer to *Section 5 Cable and Wire Standards, page 85*, for detailed wire and connection information.
14. Attach the 6-pin serial communication mating connector to the Serial Communication (cable 8) cable.
15. Connect the Earth ground wire, if available, to the crimp ring terminal inside the Mounting Plate. Refer to *Figure 2.14* above.

Note: The Earth ground is not provided with the VG4-A-ARMPLATE kit; it is a ground connection made at the installed location.
16. After making the harness connections to the Mounting Plate, rotate the Pendant Arm to close and tighten the two (2) captive screws to 10-12 N-m (90-105 in.-lbs).
17. Refer to *Section 2.9 Assemble Pendant in Packing Box, page 31*, to continue the VG4 AutoDome Installation procedure.



NOTICE! After all wiring is complete, close the cover door and tighten the two (2) captive screws on the cover door to 10-12 N-m (90-105 in.-lbs).

2.9

Assemble Pendant in Packing Box

The AutoDome Pendant must be assembled before attaching it to the pendant arm. The Pendant includes a Housing, Camera Module, and Bubble.

Note: The Pendant Housing box is designed to hold the Pendant Housing in-place during the assembly of the Pendant.

1. Open the top of the box containing the Pendant Housing, and remove the two cardboard inserts.
2. Remove the plastic bag from the Pendant Housing, and place the housing back into the packing box.
3. Remove the Camera Module from its packing box and remove the protective plastic bag.

4. Align the yellow locking tab on the base of the Camera Module to the yellow label on the CPU board and gently seat the camera into its connector.

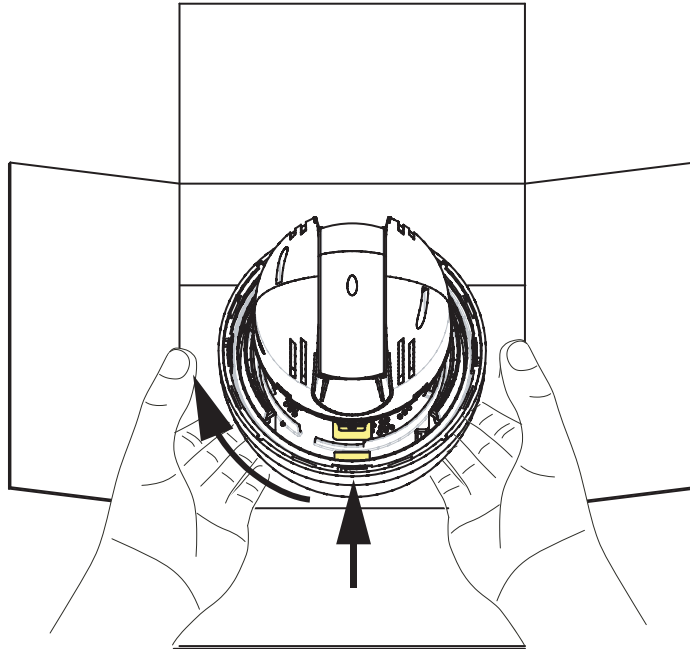

Figure 2.15 Align and Attach Camera Module

5. Rotate the yellow locking tab of the Camera Module clockwise (approximately 60 degrees) until the Camera Module locks in place.
Note: The Camera Module must be able to rotate freely when installed in the housing.
6. If you are installing a VG4 Pressurized Environmental Housing, skip to *Section 2.11 Installing the Pressurized Environmental Housing, page 35*. You will attach the bubble to the housing in a later step.
If you are installing a normal VG4 dome, continue with step 7.
7. Remove the Bubble from its packing box, and remove the protective plastic bag.
8. Place the bubble over the Camera Module and rotate it clockwise (approximately 1/8 turn) until it locks in place. You will hear an audible click when it locks.

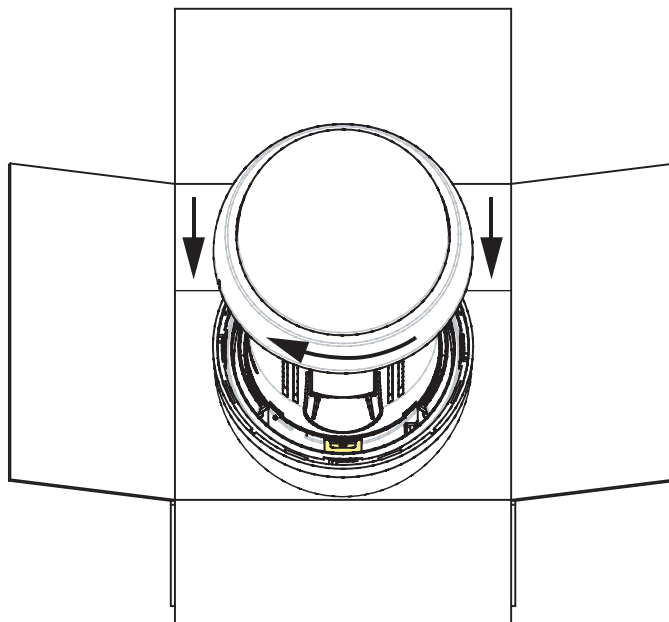

Figure 2.16 Attach bubble

2.10 Attach Pendant to Arm and Tighten



NOTICE! Before attaching the AutoDome Pendant, visually inspect the dome and arm connectors for any blocked pin holes or bent pins.

1. Tilt the bottom of the dome toward the pendant arm base and place the mounting hook, located on top of the dome housing, over the recessed hinge pin of the arm.

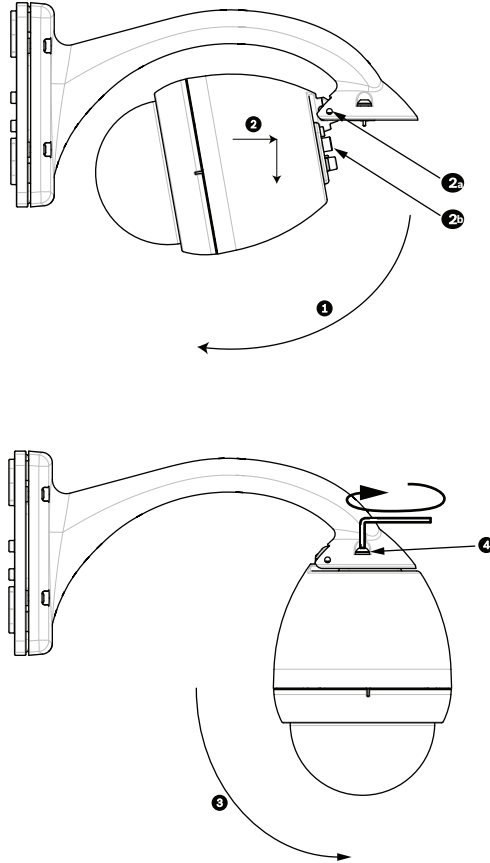

Figure 2.17 Attach Pendant to Arm

1	Tilt up.
2	Hook and drop.
2a	Recessed Hinge Pin
2b	Dome Connector
3	Rotate down to engage dome connector.
4	Tighten the two (2) mounting screws to a minimum torque of 10-12 N-m (90-105 in.-lbs).

2. Drop the dome housing down slightly to engage the dome housing hook on the Pendant Arm hinge pin, allowing the dome to rotate around the pin.
3. Rotate the dome housing down to a vertical position and gently push upward to engage the connector on top of the dome housing.



CAUTION!

If you feel any resistance when rotating the dome housing or when engaging the connector, stop immediately and start over.

4. Hold the Pendant housing in position while tightening the two (2) 5-mm Allen head mounting screws on top of the housing to **10-12 N-m (90-105 in.-lbs)**.

**CAUTION!**

You must tighten the two mounting screws to a minimum torque of 10-12 N-m (90-105 in.-lbs) to ensure a proper seal between the arm and the housing.

Removing the Pendant Bubble

To service the AutoDome Pendant, use the following procedure to remove the Bubble:

1. Using both hands, apply a counterclockwise (looking up at the dome) rotational force on the Pendant Bubble Assembly to set the bubble latch.
2. Insert a small (2 mm) straight blade screw driver into the bubble release opening in the bubble trim-ring to release the lock, and then remove the screwdriver. See the figure below.
3. Rotate the Bubble Assembly counterclockwise approximately 20 degrees until the bubble assembly releases from the Pendant Housing.

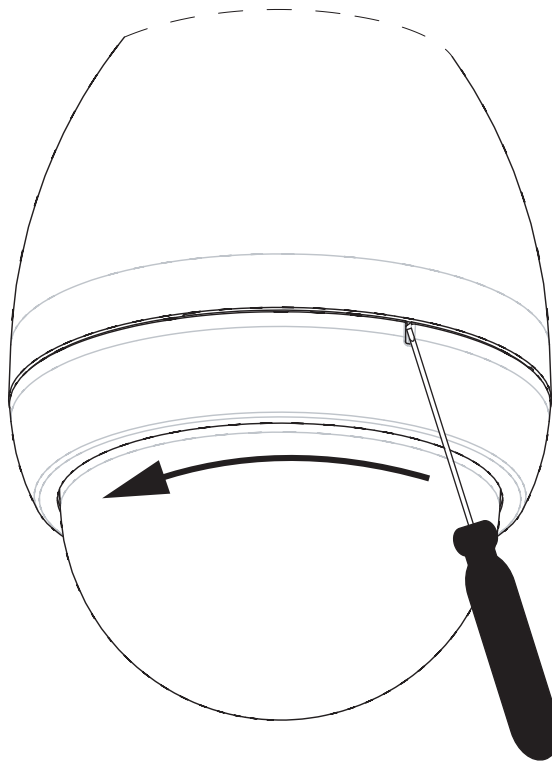

Figure 2.18 Pendant Bubble Release Opening

2.11 Installing the Pressurized Environmental Housing

The VG4 Pressurized Environmental Housing provides maximum protection for CCTV cameras and lenses. The charge of dry nitrogen inside the housing eliminates the effects of moisture, dust, insects, and corrosive exhaust fumes.

This section provides the details and instructions for mounting the pendant to the arm, calibrating the pressure sensor, and pressurizing the dome with dry nitrogen.

Note: If you are installing a normal VG4 AutoDome (not a pressurized dome), skip the remainder of this chapter.

2.11.1 Important Installation Safeguards

- Always use safety goggles when servicing the unit.
- Never use an unregulated gas supply to pressurize the enclosure. The valve should be regulated with a maximum of 86.18 kPa (12.5 psi) output.
- PRESSURIZE USING DRY NITROGEN ONLY!



CAUTION!

Be sure to periodically examine the unit and its supporting structure. If the dome shows any signs of wear, such as stress cracking, it should be replaced immediately.

2.11.2 VG4 Pressurized Environmental Housing

The VG4 Pressurized Environmental Housing differs from normal VG4 housings because of the addition of a Schrader fill valve, located on the back side of the housing, and a pressure relief valve, located on the top of the housing cap.

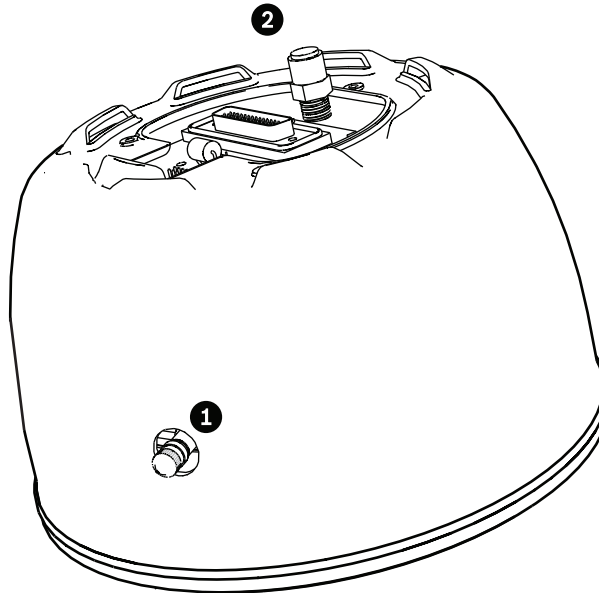

Figure 2.19 VG4 Pressurized Environmental Housing

1	Schrader Fill Valve
2	Pressure Relief Valve

2.11.3

Required Equipment

To pressurize the housing, you need the following:

- **A tank of dry nitrogen**

Nitrogen is a readily available gas; check your local yellow pages for a medical or industrial gas provider. If the tank is to be carried from location to location, a size of 1 cubic meter (40 cubic feet) is recommended. This tank size should be enough to refill 30 individual housings. Tanks of dry nitrogen can be kept for several years



CAUTION!

Handle the tanks with care. Although nitrogen is an inert gas, the tank is highly pressurized and if the valve or regulator is damaged, the tank could be dangerous.

- **A regulator on the tank**

A regulator for the tank is required, even though the tank is fitted with a standard 580 fitting. Recommended regulators for the tank are: Harris #9296-15-580 or #425-15-580. For local distribution, contact Harris at 800-241-0804.

- **A hose with an air chuck to connect the regulator to the housing's fill valve**

The Schrader fill valve, also called a dill valve, is similar to the air intake valve on car tires or bicycle tires. To connect the regulator to the purge valve on the housing, you need a hose with a 1/4-inch barb on one end and an air chuck on the other. The barb connects to the regulator and the air chuck connects to the Schrader valve. You may obtain these hoses at local auto parts stores.

- **A T25 pin-in Torx driver**

This tool is required to tighten the eight (8) captive screws that secure the bubble to the housing. A small pin-in Torx tool comes with the VG4 Pressurized Environmental Housing module, but you may prefer to use a larger driver.

2.11.4 Attaching the Housing to the Arm



NOTICE! Before attaching the AutoDome Pendant, visually inspect the dome and arm connectors for any blocked pin holes or bent pins.

1. Tilt the bottom of the dome toward the pendant arm base and place the mounting hook, located on top of the dome housing, over the recessed hinge pin of the arm.

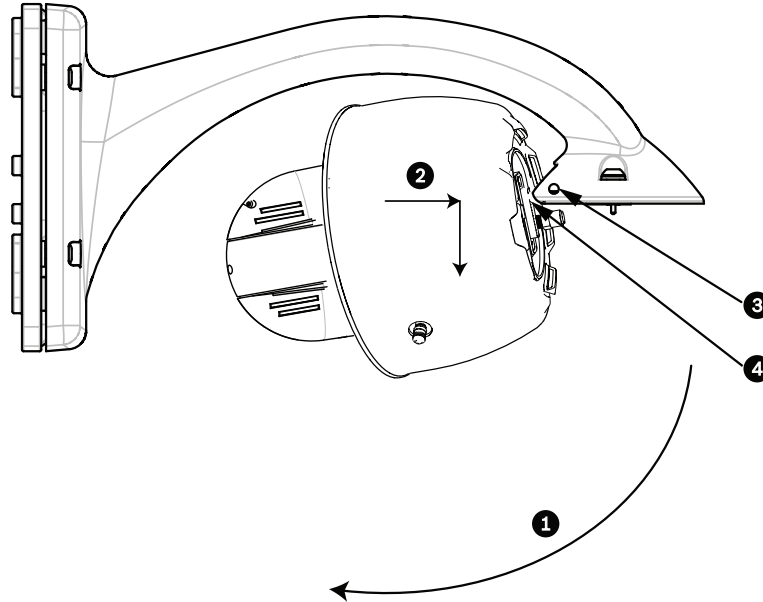

Figure 2.20 Attach AutoDome to Pendant Arm

1	Tilt up
2	Hook and drop
3	Recessed Hinge Pin
4	Dome Connector

2. Drop the dome housing down slightly to engage the dome housing hook on the Pendant Arm hinge pin, allowing the dome to rotate around the pin.
3. Rotate the dome housing down to a vertical position and gently push upward to engage the connector on top of the dome housing.
4. Hold the housing in position while tightening the two (2) 5-mm Allen head mounting screws on top of the housing to **10-12 N-m (90-105 in.-lbs)**.



CAUTION!

If you feel any resistance when rotating the dome housing or when engaging the connector, stop immediately and start over.

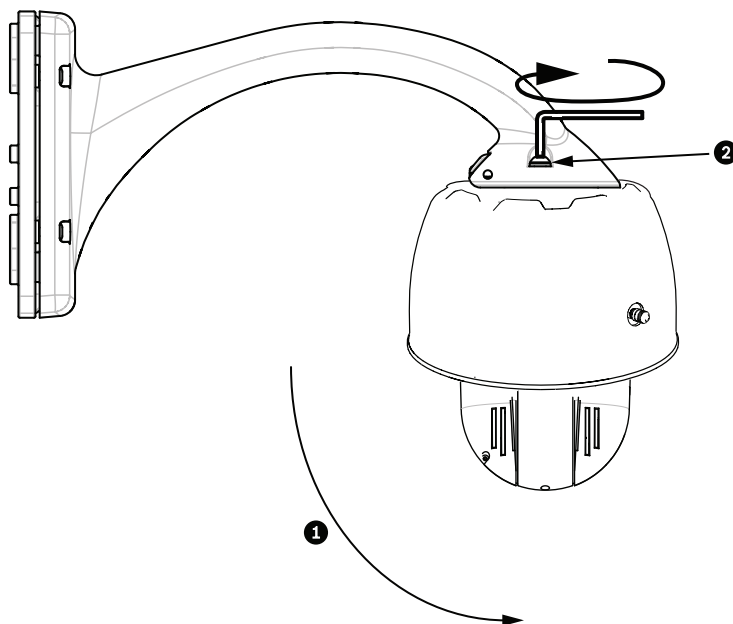

Figure 2.21 Tighten Pendant Connection

1	Rotate down to engage dome connector.
2	Tighten the two (2) mounting screws to a minimum torque of 10-12 N-m (90-105 in.-lbs).



CAUTION!

You must tighten the two mounting screws to a minimum torque of 10-12 N-m (90-105 in.-lbs) to ensure a proper seal between the arm and the housing.

2.11.5

Calibrating the Pressure Sensor

The VG4 Pressurized Environmental Housing features an internal low-pressure sensor alarm which must be calibrated to the local atmospheric pressure. The heater/blower/pressure sensor power must be connected to do calibration.

You must perform the calibration procedure within four (4) minutes of powering up the VG4 unit or the sensor will not store the calibration data. If you should miss this calibration period, power off the unit and restart the procedure.

Once the sensor is calibrated no further adjustment is necessary. You may recalibrate the unit, however, anytime that power is shut off to the VG4 unit.

The procedure is as follows:

1. Apply power to the VG4 unit. The green LED, located at the left side of the camera module, illuminates and remains constant.
2. After approximately 30 seconds the LED begins to blink, indicating that the VG4 unit is ready for calibration.

3. Using a thin screwdriver press and hold the red calibration switch, located on the opposite side of the LED.
Once the sensor is calibrated and the data is permanently stored, the LED shuts off and you can release the calibration switch.

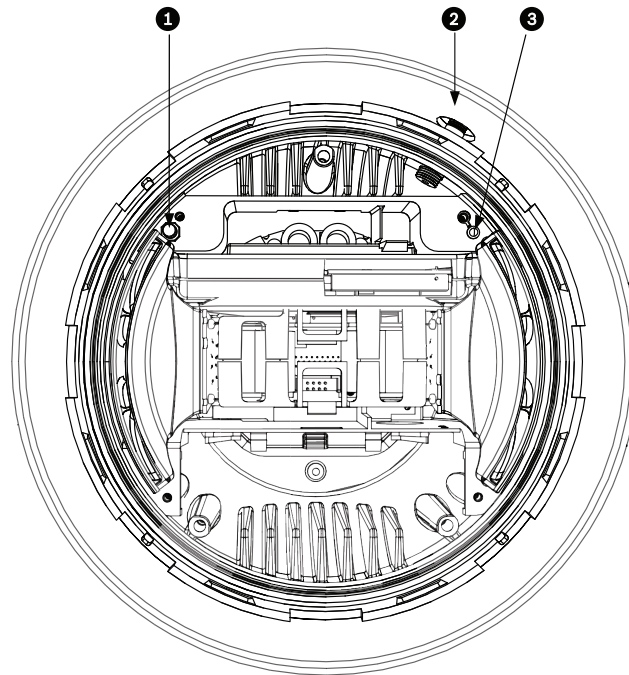

Figure 2.22 Location of the Calibration Switch

1	Calibration Switch
2	Schrader Fill Valve
3	LED

4. Turn the power off to the VG4 unit.

2.11.6

Attaching the Bubble to the Housing

1. Remove the bubble from the box and then remove the bubble from the protective plastic bag.
2. Disengage the four tabs from the white trim skirt ring that surrounds the bubble. Then, move the trim skirt ring towards the bubble opening to remove.

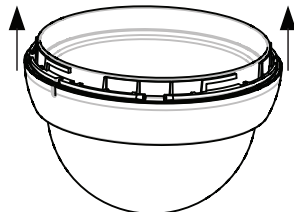

Figure 2.23 Bubble with Trim Skirt Ring

3. Discard the trim skirt ring. It is not needed for the Pressurized Environmental Housing installation.
4. Clean the inside of the bubble. Refer to *Section 7 Bubble Handling and Cleaning, page 100*, for cleaning instructions and for recommended products.
5. Clean the groove inside the rubber bubble gasket with pressurized air to remove debris. Then, using alcohol, clean the groove to remove oil and grease.
6. Insert the sealing edge of the bubble into the groove in the rubber bubble gasket.

- Place the bubble support ring over the bubble and align the eight (8) captive screws with the threaded inserts on the plastic gasket ring.

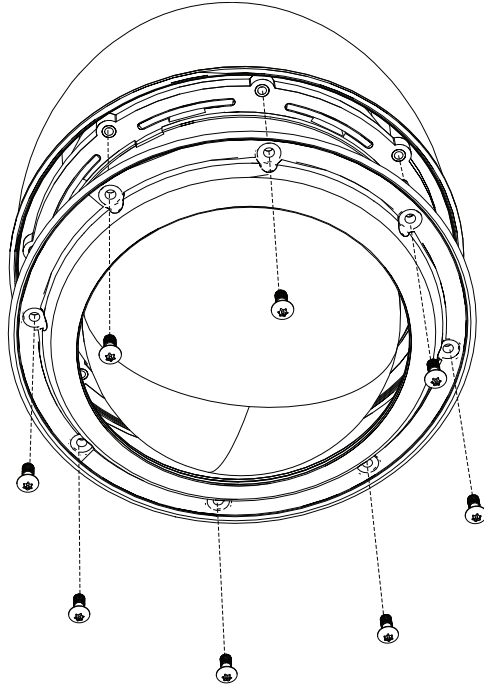

Figure 2.24 Attach Support Ring

- Loosely tighten the captive screws with the T25 pin-in Torx tool using a diametrically opposed tightening pattern, until the gap between the bubble support ring and the housing closes.

Start tightening screw 1, then tighten screw 2. Next, tighten screw 3 and continue to screw 4. Continue tightening the screws in this pattern.

Note: Make sure not to overtighten the screws.

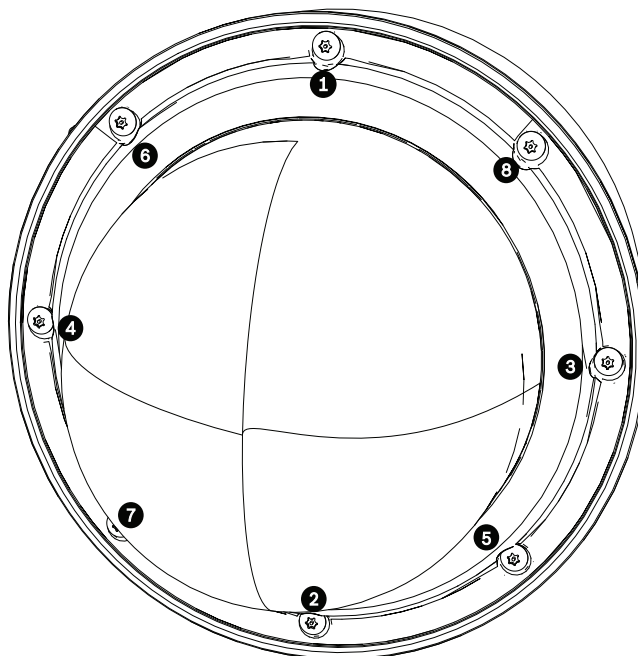

Figure 2.25 Bubble Support Ring Tightening Pattern

9. Tighten the screws again, using the same diametrical pattern, to a torque of 0.90 N-m (8 in.-lbs). Use a dial-indicator torque screwdriver to check the torque.
10. Begin a second round of tightening, using the same diametrical pattern, until the screws reach a torque of 1.58 N-m (14 in.-lbs).
11. Continue tightening the screws, using the same diametrical pattern, to reach a torque of 2.26 N-m (20 in.-lbs).
12. Finish tightening the screws, using the same diametrical pattern, to reach a final torque of 2.71 N-m (24 in.-lbs).
13. Perform a final check, using the same diametrical pattern, of each screw. Adjust any screw that is below 2.71 N-m (24 in.-lbs) of torque.

2.11.7

Pressurizing the Housing

The VG4 Pressurized Environmental Housing can maintain a maximum internal pressure of 75.84 kPa (11 psi) \pm 5%. Above 75.84 kPa (11 psi), the pressure relief valve cracks and then seats at a pressure of 65.50– 68.95 kPa (9.5–10 psi).

Follow these steps to pressurize the housing:

1. Set the gauge on the regulator to 86.18 kPa (12.5 psi).
2. Place the air chuck on the Schrader fill valve, just as you would on a tire, and press down to begin filling the housing. The dome should reach maximum pressure in under ten seconds.
Excess air should vent from the pressure relief valve after the maximum internal pressure of 75.84 kPa (11 psi) is reached.
3. Remove the air chuck from the Schrader fill valve.
4. Attach a pressure gauge to the Schrader fill valve. Ensure that the pressure inside the housing is between 62.05 kPa (9 psi) and 79.98 kPa (11.6 psi).
5. After you verify the pressure, reconnect the air chuck and purge the remaining air inside the housing for five (5) minutes.

2.11.8

Servicing the VG4 Pressurized Environmental Housing

To service the AutoDome Pendant, use the following procedure to remove the Bubble:

1. Purge the nitrogen from inside the Pressurized Environmental Housing and bubble.
2. Loosen, but do not fully remove, the eight (8) captive screws using a T25 pin-in Torx driver from the bubble support ring.
3. Support the bubble with your hand to ensure that it does not fall as you fully remove the captive screws using an alternating pattern.
4. Remove the bubble and the bubble support ring.

3 Installing Roof Parapet and Pipe Mounts

3.1 Unpacking

This equipment should be unpacked and handled with care. If an item appears to have been damaged in shipment, notify the shipper immediately.

Verify that all the parts listed in the product's Parts List below are included. If any items are missing, notify your Bosch Security Systems Sales or Customer Service Representative. See Section 1.5 for Customer Support and Service contact information.

The original packing carton is the safest container in which to transport the unit and must be used if returning the unit for service. Save it for possible future use.

3.1.1 Parts List

The following table lists the parts included with the Roof Parapet and Pipe mount packages:

Mount Kit Options	Part Numbers
Parapet (Roof) Mount with one of the following Power Supply Boxes:	VG4-A-9230
– Power Supply Box with 120 VAC transformer or 230 VAC transformer	VG4-A-PSU1 VG4-A-PSU2
– Power Supply Box with Fiber Optic Module and 120 VAC transformer, or 230 VAC transformer	VG4-A-PSU1F VG4-A-PSU2F
– Power Supply Box without transformer (24 VAC) and with Fiber Optic Module	VG4-A-PSU0F
Optional Flat Roof Mount Adapter for VG4-A-9230 Mount (not included)	LTC 9230/01
Pipe Mount with one of the following Power Supply Boxes:	VG4-A-9543
– Power Supply Box with transformer 120 VAC or 230 VAC transformer	VG4-A-PSU1 VG4-A-PSU2
– Power Supply Box with Fiber Optic Module and 120 VAC transformer or 230 VAC transformer	VG4-A-PSU1F VG4-A-PSU2F
– Power Supply Box without transformer (24 VAC) and with Fiber Optic Module	VG4-A-PSU0F
Bubble	
– Clear Bubble with white trim ring, or – Tinted Bubble with white trim ring – Optional white bubble support ring for Pressurized Environmental Housing	VG4-SBUB-PCL VG4-SBUB-PTI

Roof Parapet and Pipe Mount Parts List



Trim Skirt (optional)

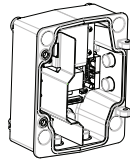

Power Supply

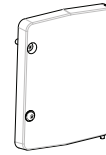

Power Supply cover

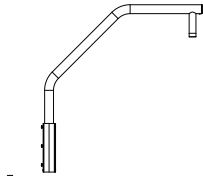

Roof Parapet Mount

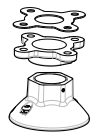

Pipe Mount Assembly

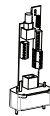

Interface Module



Environmental Shield (optional)



Pressurized Environmental Housing (optional)



Pendant Housing



COMMS Module

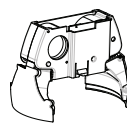

Thermal Module (optional)

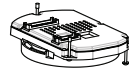

CPU Module



Camera Module



Dome Bubble



Bubble Support Ring for Pressurized Environmental Housing (optional)

3.1.2

Description

Chapter 3 details how to install a VG4 AutoDome to a Roof Parapet or to a Pipe mount. Any differences to the installation between these two mounting systems are noted. See Chapter 2 if you are installing a Pendant Arm to a Wall, Corner, or Mast (or pole) or see Chapter 4 if you are mounting an In-ceiling AutoDome.

The VG4-A-9230 Series are stationary mounts intended for rooftop parapet vertical walls. They are made of light weight aluminum with a corrosion-resistant finish and are used for all Bosch AutoDome Modular Camera systems up to a rated load of 29 kg (64 lb). These mounts can be fitted to the inside or outside of parapet walls and can swivel for ease of positioning and for servicing the AutoDome.

3.1.3

Tools Required

- 5 mm Allen wrench (supplied)
- Small straight blade screwdrivers ~ 2.5 mm (0.1 in.) – 3.1 mm (1/8 in.)
- Medium straight blade screwdriver
- No. 1 and No. 2 Phillips screwdrivers
- Socket wrench and 9/16 in. socket
- Pipe Wrench
- Barrel connector (if installing a fiber optic model)
- Pin-in Torx tool (supplied) or a T25 pin-in Torx driver (for Pressurized Environmental Housing)
- Dial-indicator Torque Screwdriver (for Pressurized Environmental Housing)

3.2

Pre-installation Check List

1. Determine the location and distance for the power supply box based on its voltage and current consumption. See *Section 5 Cable and Wire Standards, page 85* for wiring information and distances.
2. Use only UL listed liquid tight strain reliefs for conduits to the Power Supply Box to ensure that water cannot enter the box. You must use water tight conduits and fittings to meet NEMA 4 standards.



NOTICE! Power and I/O cabling must be routed separately inside different permanently earthed metal conduits.

3. Install all rough wiring including: power, control, video coax, alarms I/O, relay I/O, and fiber optic cabling. See *Section 5 Cable and Wire Standards, page 85* for video and control protocol methods.



WARNING!

External interconnecting cables are to be installed in accordance to NEC, ANSI/NFPA70 (for US application) and Canadian Electrical Code, Part I, CSA C22.1 (for CAN application) and in accordance to local country codes for all other countries.

Branch circuit protection incorporating a 20 A, 2-pole Listed Circuit Breaker or Branch Rated Fuses are required as part of the building installation. A readily accessible 2-pole disconnect device with a contact separation of at least 3 mm must be incorporated.

4. Choose the appropriate VG4 AutoDome model (indoor or outdoor) for the environment in which it will be used.
5. If this AutoDome installation utilizes the AutoTracker feature, refer to *Section A Installation Notes for AutoTracker, page 101*, before mounting the AutoDome.

- Choose the appropriate mounting kit to use depending on the location of the AutoDome: Parapet (Roof) mount or the Pipe mount.

**CAUTION!**

Select a rigid mounting location to prevent excessive vibration to the AutoDome camera.

3.3**Mount Power Supply Box**

Before mounting the Power Supply Box decide if you will be wiring the box through the holes in the bottom or back of the box. If wiring the box through the back, move the two (2) seal plugs to the bottom holes before mounting.



NOTICE! Use 3/4-inch NPS (20-mm) fittings for the holes on the bottom and back of the box. Use 1/2-inch NPS (15-mm) fittings for the side holes. See *Section 3.1.1 Parts List, page 42*, for an illustration.

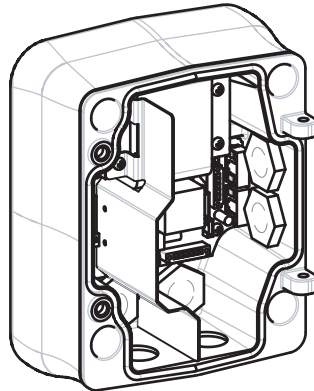

Figure 3.1 Wall Mount Power Supply

- Use the wall mount template supplied in the packaging box to locate the four (4) mounting holes for the Power Supply Box.
- Drill four (4) holes for the mounting anchors. If installing outdoors, apply a weatherproof sealant around each hole at the mounting surface.
- Place the Power Supply Box into the optional Trim Skirt.
- Secure the Power Supply Box to the wall using four (4) corrosion-resistant stainless steel studs (not included).



NOTICE! A stud diameter of 6.4 mm (1/4 in.) or 8 mm (5/16 in.), able to withstand a 120 kg (265 lb) pull-out force is recommended.

- Attach the 3/4 in. (20 mm) watertight pipe fittings (not supplied) to the holes of the Power Supply Box through which you will run the power, video, and control data wires.

3.3.1 Attach Cover Door

1. Compress the bottom hinge pin by pushing the pin lever down and then rotate it behind the Hinge Pin Stop. The power box Cover Door provides a Hinge Pin Stop to hold the bottom hinge open while attaching the door.

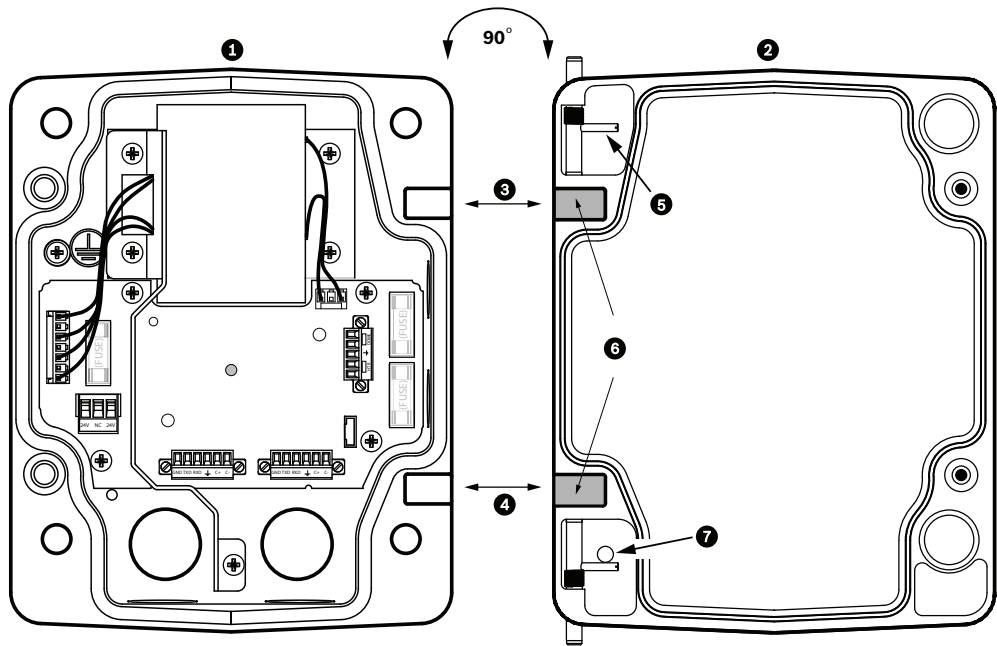

Figure 3.2 Align Cover Door Hinge to Power Box

1	Power Supply Box	5	Hold Hinge Pin Open
2	Cover Door	6	Open Position
3	Align Top Hinge	7	Hinge Pin Stop
4	Align Bottom Hinge		

2. Open the top hinge by pushing its pin lever outward and holding it open.
Note: Both Hinge Pins must be fully compressed to open (unlock) the female hinges of the Cover Door before proceeding to the next step.
3. While holding the top hinge pin open, position the Cover Door to the Power Supply Box and align its hinges.
4. When the hinges are aligned, release the top hinge pin to engage its mating hinge on the power box. Then release the bottom hinge pin from the Hinge Pin Stop to complete attaching the Cover Door to the Power Supply Box.



NOTICE! After all wiring is complete, close the cover door and tighten the two (2) captive screws on the cover door to 10-12 N·m (90-105 in.-lbs) to ensure the Power Supply Box is watertight.

3.4 Route Wires and Attach Connectors

Power wires must be routed to the left (front) side of the Power Supply Box through a separate conduit. All video, control, and alarm wires must be routed through a second conduit to the right side of the box. See *Section 5 Cable and Wire Standards, page 85* for methods of transmitting video and data, and for wire specifications.



WARNING!

External interconnecting cables are to be installed in accordance to NEC, ANSI/NFPA70 (for US application) and Canadian Electrical Code, Part I, CSA C22.1 (for CAN application) and in accordance to local country codes for all other countries.

Branch circuit protection incorporating a 20 A, 2-pole Listed Circuit Breaker or Branch Rated Fuses are required as part of the building installation. A readily accessible 2-pole disconnect device with a contact separation of at least 3 mm must be incorporated.

There are two possible methods to route the video, control, and alarm wires:

- One is to route the video, control, and alarm wires through the conduit fitting on the right (front) side of the Power Supply Box and out to the AutoDome Interface Board.

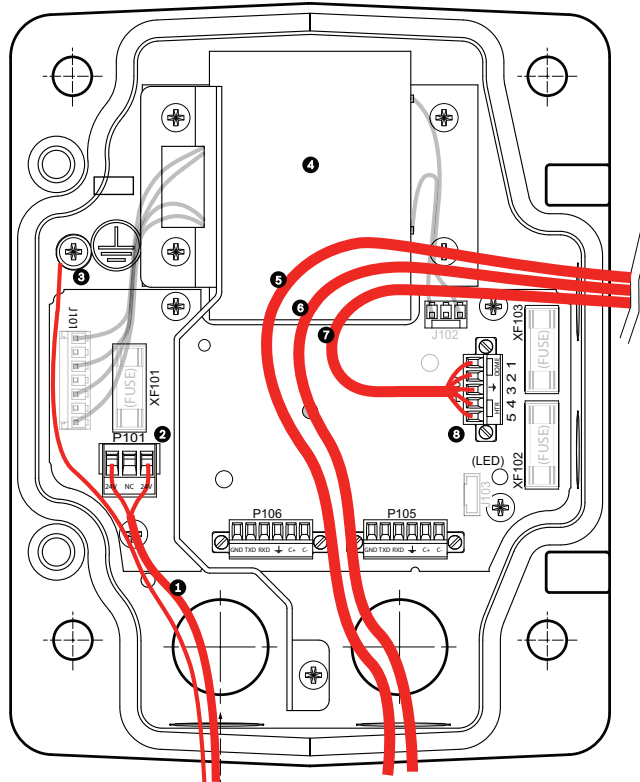

Figure 3.3 VG4-A-PSU1 or VG4-A-PSU2 Power Supply Box

1	120 VAC/230 VAC Power In	5	Video Wire
2	P101 Connector	6	Control Wire
3	Ground Connection	7	24 VAC Power Out
4	Transformer	8	P107 Connector

- The second method is to bypass the Power Supply Box and route the video, control, and alarm wires directly to the Interface Board. You connect only the power wires inside the Power Supply Box.

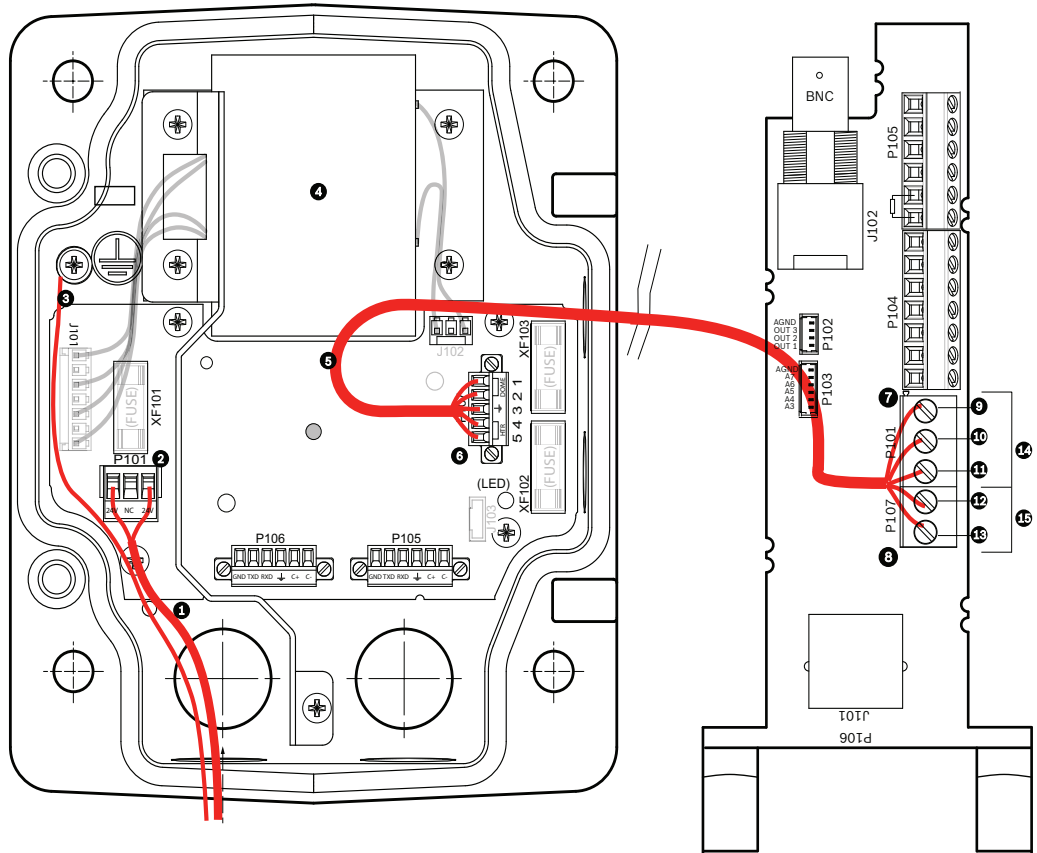

Figure 3.4 VG4-A-PSU1 or VG4-A-PSU2 Power Supply Box Connected to Pipe Interface Board

VG4-A-PSU1/VG4-A-PSU2		Pipe Interface Board	
1	120 VAC/230 VAC Power In	7	P101 Connector
2	P101 Connector	8	P107 Connector
3	Ground Connection	9	24 VAC Power In (to AutoDome)
4	Transformer	10	Earth Ground
5	24 VAC Power Out	11	24 VAC Power In (to AutoDome)
6	P107 Connector	12	24 VAC Power In (to Heater)
		13	24 VAC Power In (to Heater)
		14	AutoDome Power
		15	Heater Power



NOTICE! Fiber Optic Models require that the Biphase control wires be routed from the Power Supply Box P106 connector out to the Pipe Interface Board P105 connector.

3.4.1 Wiring the Power Supply Box

1. Route the high voltage 115/230 VAC lines through the conduit fitting on the left side of the box.



NOTICE! The Power Supply Box with transformer comes with a barrier that separates the high voltage side on the left from the low voltage 24 VAC side on the right.

2. Cut and trim the high voltage 115/230 VAC power and ground wires with sufficient slack to reach their connector terminal in the box, but not so long as to be pinched by or to obstruct closing the Cover Door. See *Section 3.1.1 Parts List, page 42*, for connector location.
3. Attach the supplied 3-pin Power Plug to the incoming high voltage power wires in the box. See connector P101 in *Table 3.1, Page 52*.
4. Route the low power 24 VAC wires from the right side of the Power Supply Box out to where the AutoDome will be mounted. Attach the supplied 5-pin 24 VAC Dome plug to the wire ends inside the box. See connector P107 in *Table 3.1, Page 52*.
5. If you are using UTP for video or Ethernet, route the UTP cable out to where the AutoDome will be mounted. See *Section 5 Cable and Wire Standards, page 85* for fiber optic specifications.



NOTICE! All video, control, and alarm wires either pass through the Power Supply Box or bypass it and connect directly to the Pipe Interface Board.

3.4.2 Wiring the Fiber Optic Model

1. If installing a Fiber Optic model, bring the fiber optic cable into the right side of the power supply box.
2. Route a video coax cable from the Power Supply Box to the Pipe Interface Board. Then attach a BNC connector to the cable end inside the Power Supply Box. See *Section 5 Cable and Wire Standards, page 85* for fiber optic specifications.



NOTICE! You will need a barrel connector (not supplied) to connect the BNC connector from the Pipe Interface Board coax cable to the Fiber Optic Module BNC connector.

3. Route the control wires from the Power Supply to the Pipe Interface Board. Then attach the supplied six (6) pin control data connector to the wires in the Power Supply Box.

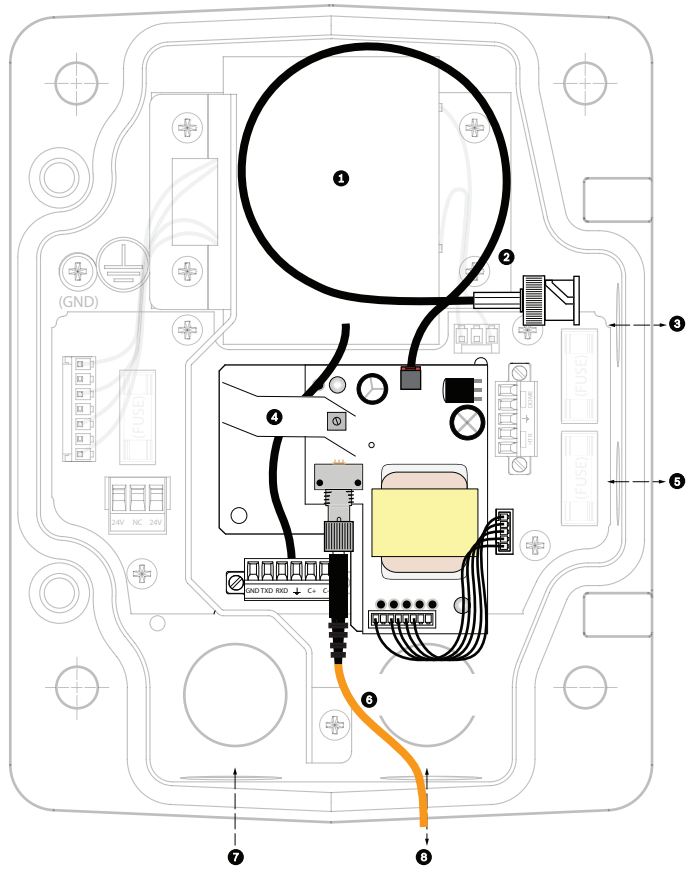

1	Transformer	5	In/Out
2	BNC to Dome	6	ST Connector (Fiber)
3	In/Out	7	Power In
4	From Arm Harness	8	Data In/Out

3.4.3 Power Supply Box Connections

The following figure is a detailed illustration of the Roof or Pipe Mount Power Supply Box, which includes the fuse specifications.

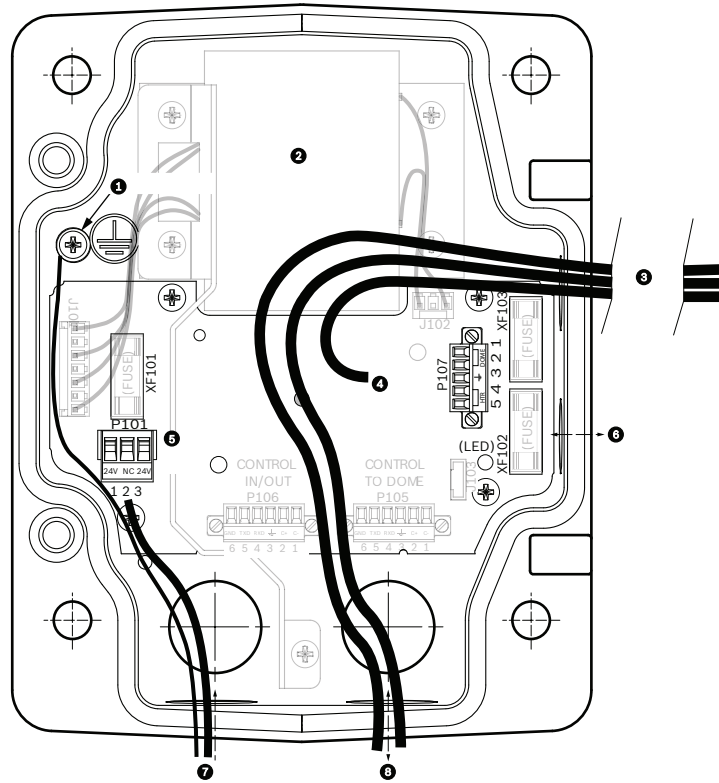

1	Ground Screw	5	Power In
2	Transformer (115/230 VAC Modes)	6	In/Out; 1/2 in. (15 mm) NPS Fitting
3	In/Out to Dome	7	Power In; 3/4 in. (20 mm) NPS Fitting
4	24 VAC to Dome Interface Board	8	Control Data and Video In/Out; 3/4 in. (20 mm) NPS Fitting



WARNING!

Fuse replacement by qualified service personnel only. Replace with same type fuse.

Fuse Specifications			
Volts	XF101 Mains	XF102 Camera	XF103 Heater
24 V	T 5.0 A	T 2.0 A	T 3.15 A
115 V	T 1.6 A	T 2.0 A	T 3.15 A
230 V	T 0.8A	T 2.0 A	T 3.15 A

The following table lists the Power Supply Box connectors:

No.	Connector	Pin 1	Pin 2	Pin 3	Pin 4	Pin 5	Pin 6
	Ground	Grounding Screw					
P101	115/230 VAC or 24 VAC Power In	Line	NC	Neutral			
P105	Control to Dome (Fiber Optic Model)	C- (Biphase)	C+ (Biphase)	Earth Ground	RXD (+) (RS-232/485)	TXD (-) (RS-232/485)	Signal Ground
P106	Control In/Out (Optional)	C- (Biphase)	C+ (Biphase)	Earth Ground	RXD (+) (RS-232/485)	TXD (-) (RS-232/485)	Signal Ground
P107	24 VAC Power to Dome Plug	Dome 24 VAC	Dome 24 VAC	Earth Ground	Heater (24 VAC)	Heater (24 VAC)	

Table 3.1 Power Box Connections

3.5

Installing the VG4-A-9230 Roof Parapet Mount

This section details the installation steps for the Roof Parapet Mount. If you are installing a pipe mount, see *Section 3.6 Installing the VG4-A-9543 Pipe Mount, page 55*, for instructions.

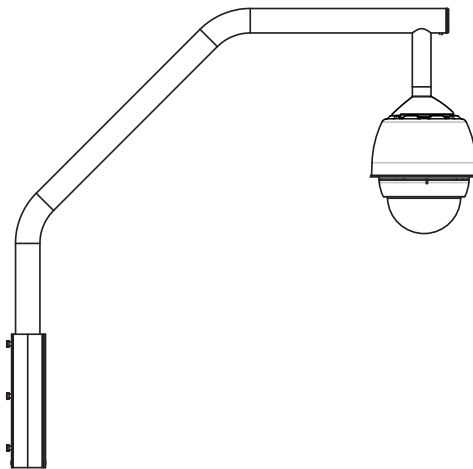

Figure 3.5 VG4-A-9230 Parapet Roof Mount

1. Determine the wall location on the roof for the AutoDome and use the Parapet wall mount bracket as a template to mark the hole locations.



NOTICE! Allow enough room below the Parapet Mount Bracket to route the video, control and alarm wires up through the Parapet arm. In certain installations you may have to lift the Parapet arm for the AutoDome to clear the top of the wall when it is swung into position. Provide enough slack in the wires to rotate the pipe arm over the roof and back when camera maintenance is required.

2. Prepare the mounting surface for the type of fastener by drilling holes for the mounting anchors as required.

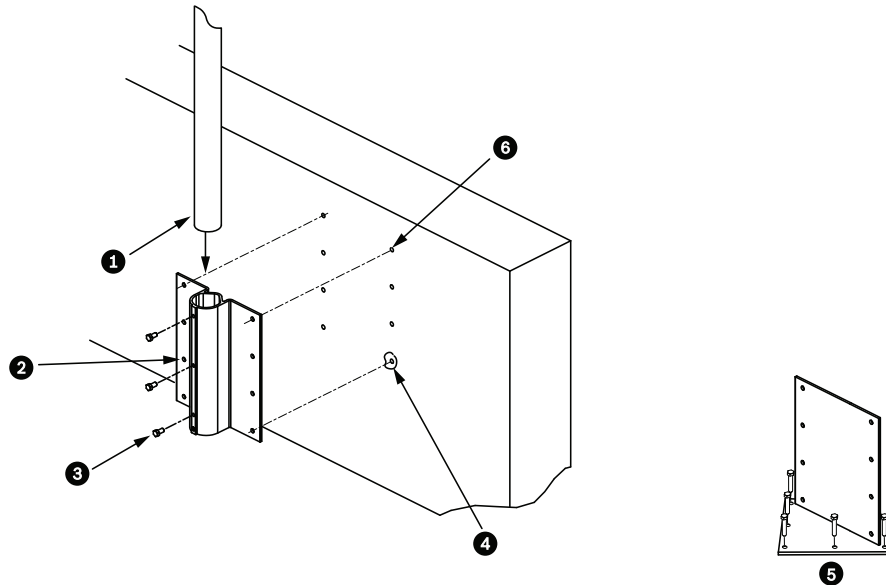

Figure 3.6 Parapet Wall Mount Bracket and Roof Mount Plate

1	Pipearm	4	Apply sealant around each fastener hole
2	Parapet Wall Bracket	5	Roof Mount Plate
3	3/8-16 SS Hex Head Bolt (supplied)	6	Use a minimum of six (6) fasteners (not supplied). Eight (8) fastener holes shown.



NOTICE! Fasteners are not supplied with the Roof Parapet Mount Kit since it depends on the material to which it is attached. The material must accommodate a minimum pull out strength of 275 kg (600 lbs). For example, 19 mm (3/4 inch) minimum for plywood. Fasteners can include bolts, studs, or lag bolts. All fasteners must be made of corrosion-resistant stainless steel, with a diameter of 10 mm (3/8 inch).

All bolts must fully extend through the mounting surface and be secured with a flat washer, lock washer and a nut. All studs must be anchored to concrete or welded to a steel backing plate. Anchor bolts can be used for blind structures where there is no access to the rear.

3. Apply a weatherproof sealant around each fastener hole at the mounting surface.
4. Attach the Parapet Wall Bracket using at least six (6) stainless steel fasteners, three (3) on each side (the bracket has eight (8) holes). Be careful not to over tighten the fasteners because it may strip the threads. If attaching the parapet mount to a flat roof, attach the optional LTC 9230/01 Roof Mount Plate to the roof and then attach the Parapet Wall Bracket to the Roof Mount Plate.
5. Insert the Parapet Pipe Arm into the mounting bracket until it bottoms in the bracket.

- Remove the End Cap from the front of the arm and feed the video, control, and power wires up through the bottom of the pipe arm and out the front end.

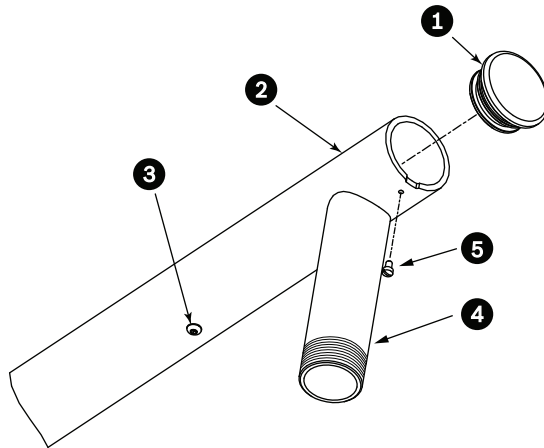

Figure 3.7 VG4-A-9230 Parapet Mount

1	End Cap with O-ring
2	Parapet Pipe Arm
3	1/4-20 SS Cap Screw
4	Down Pipe
5	10-24 SS Pan Head Screw

- Fold the video, control, and power wires back at the front end of the arm and route them down and out through the Down Pipe. Then replace the End Cap.
- Wrap at least five layers of Teflon tape around the Down Pipe threads.
- Apply the supplied thread sealant to the Down Pipe threads:
 - Make sure all surfaces are clean and dry.
 - Apply a bead of sealant completely around the leading threads of the male fitting.
 - Force the adhesive into the threads to thoroughly fill all voids.
- Thread the Dome Cap onto the down pipe and tighten securely. See the illustration below.



WARNING!

You must thread the Dome Cap onto the Down Pipe until it is tight. Failure to do so can result in damage, serious injury, or death.

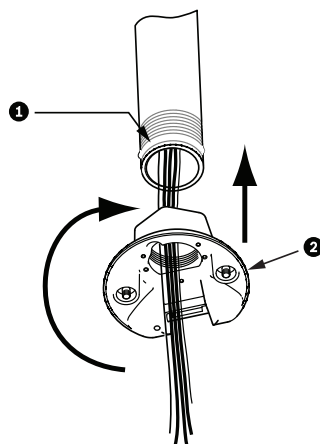

Figure 3.8 Attach Dome Cap

1	Thread Sealant or tape
2	Dome Cap

11. Run a bead of RTV Silicon sealant around the down pipe/Dome Cap interface to seal any gaps between the down pipe and the Dome Cap.
12. Proceed to *Section 3.7 Wire the Pipe Interface Board, page 57.*



NOTICE! Use a guy-wire to aid in stabilizing the Parapet Arm. Replace the 1/4 inch cap screw with a threaded 1/4-inch stainless steel eye bolt (not supplied). Loop the guy-wire through the eye bolt and attach both ends to anchor spots on the roof. See *Figure 3.7, Page 54.*

3.6

Installing the VG4-A-9543 Pipe Mount

This section details the installation steps for the VG4-A-9543 Pipe Mount. If you are installing the Roof Parapet mount, see *Figure 3.7, Page 54,* for instructions.



NOTICE! Customer must supply 1-1/2 inch (NPS) pipe threaded on both ends with a minimum length of 5 inches (12.7 cm).

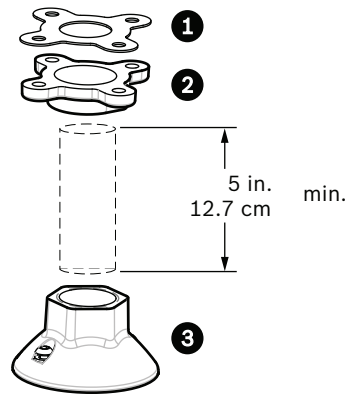

Figure 3.9 Pipe Mount

1	Gasket
2	Flange
3	Cap

1. Before installing the Top-Mounting Flange, ensure there is an adequate opening in the ceiling or mounting structure for the wires to pass through.
2. Secure the pipe Flange with supplied gasket to the ceiling or other supporting structure using four (4) 10-mm (3/8-inch) diameter fasteners.



NOTICE! Each fastener must have a minimum pullout strength of 275 kg (600 lbs). The mounting material must be able to withstand this pull-out force. For example, 19-mm (3/4-inch) minimum for plywood.

3. Attach pipe (not supplied) to the Top-mounting Flange.

**WARNING!**

You must thread the pipe onto the Top-mounting Flange until it is tight. Failure to do so can result in damage, serious injury or death.

-
4. Route the power, video, control, and alarm wires through the Top-Mounting Flange and down the pipe.
 5. Wrap at least five layers of Teflon tape around the threads.
 6. Apply the supplied thread sealant to the threads on the Pipe.
 - Make sure all surfaces are clean and dry.
 - Apply a bead of sealant completely around the leading threads of the male fitting.
 - Force the adhesive into the threads to thoroughly fill all voids.
 7. Thread the Pipe Cap onto the down pipe and tighten securely to prevent leaks. See *Figure 3.9, Page 55*.

**WARNING!**

You must thread the Dome Cap onto the pipe until it is tight. Failure to do so can result in damage or serious injury or death.

3.7 Wire the Pipe Interface Board

This section provides instructions for connecting wires and cables to the Pipe Interface Board, as illustrated below. See *Section 5 Cable and Wire Standards*, page 85 for cable and wiring recommendations and specifications.

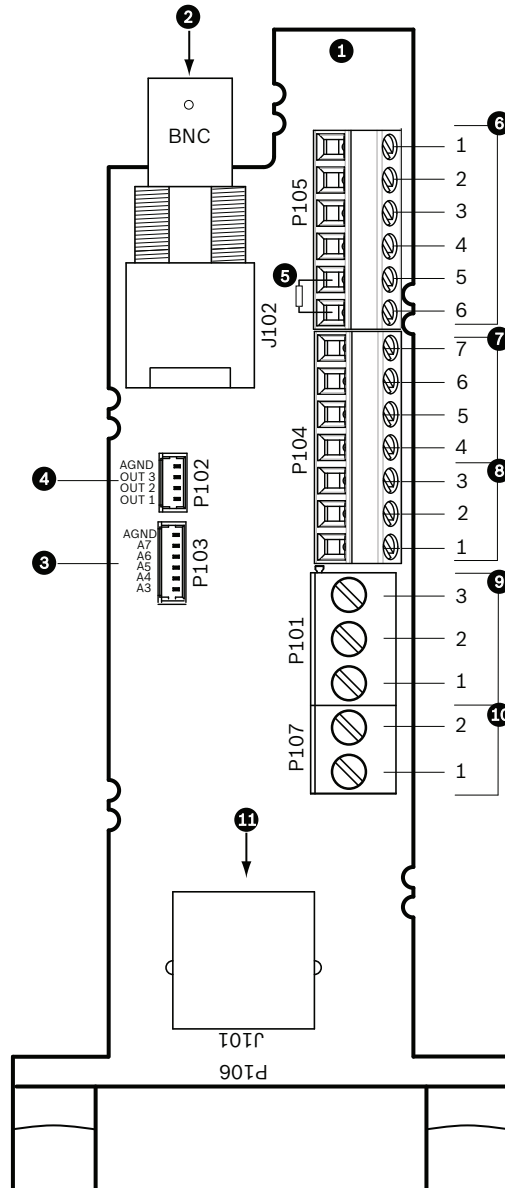

Figure 3.10 Pipe Interface Board Connections

Ref.	Description	Connector	Wire Gauge	Pin	Description
1	Pipe Interface Module				
2	Video Coax In	J102			
3	6-pin Connector Alarms In (3-7)	P103			
4	4-pin Connector Alarms Out (1-3)	P102			
5	100 Ω Resistor	P105			
6	Data In/Out	P105	AWG 26-16	1	Biphase (C-)
				2	Biphase (C+)
				3	Earth Ground
				4	RxD +
				5	TxD -
				6	Signal Ground
7	Alarms In (EOLR Supervised, 1-2)	P104	AWG 26-16	7	Ground
				6	Alarm 2
				5	Alarm 1
				4	Earth Ground
8	Relay Output	P104	AWG 26-16	3	Normally Closed
				2	Common
				1	Normally Open
9	Dome Power	P101	AWG 18-14	3	Dome 24 VAC
				2	Earth Ground
				1	Dome 24 VAC
10	Heater Power	P107	AWG 18-14	2	Heater 24 VAC
				1	Heater 24 VAC
11	RJ45 Ethernet or UTP Video	J101			
12	To AutoDome				

3.7.1

Wiring for Multiple AutoDomes

To wire multiple AutoDomes in a series, or “daisy chaining,” you must apply a terminating resistor to the last dome of the series. The Interface Board is supplied with a 100 Ω terminating resistor located between the Biphase terminals C- and C+ (pins 1 and 2) of the P105 control connector (see item 5 in *Figure 3.10* above). Remove the resistor from all but the last AutoDome Interface Board. The maximum number of AutoDomes that can be daisy chained is four (4). If using the RS485 protocol for control, switch the terminating resistor from the Biphase C+ and C- terminals to the RxD+ and TxD- terminals (pins 4 and 5) of the P105 control connector for the last dome (see item 6 in *Figure 3.10* above).

3.7.2

Connecting Wires to the Pipe Interface Board

The Pipe Interface Board contains all of the connectors for control, data, image, and power wires. Follow the procedures below to make the proper connections.



WARNING!

Use a 24 VAC Class 2 power supply only.

1. Attach a BNC connector to the video coax cable and connect it to its mating connector J102 on the Pipe Interface Board. If using UTP for video or Ethernet, attach an RJ45 connector plug to the e UTP cable and connect the plug to its mating connector J101 on the Pipe Interface Board.



WARNING!

Do not connect the RJ45 connector unless using UTP video or Ethernet. This connection causes video distortion.

2. Attach the control data in/out wires to their respective terminals on the P105 connector on the Pipe Interface Board. See *Figure 3.10, Page 57*, for an illustration of these connections.
3. Connect the 24 VAC power wires to the P101 connector on the Pipe Interface Board. If this model has a heater, connect the 24 VAC heater power wires to connector P107.



CAUTION!

To protect the AutoDome from damage due to cold temperatures, ensure that you connect the 24 VAC heater power wires to the P101 connector.

4. To connect alarm inputs and outputs, attach the supplied 6-pin Alarms In and the 4-pin Alarms Out connector plugs with flying leads to the appropriate alarm wires. Then connect the plugs to their mating connectors P103 and P102 on the Pipe Interface Board.

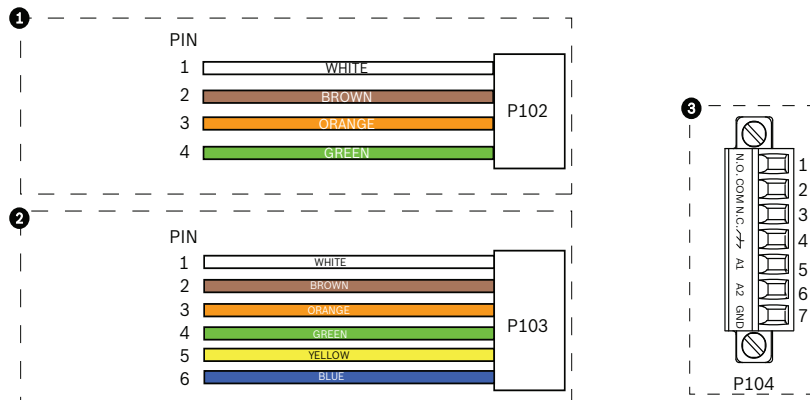

Figure 3.11 Alarm and Relay Connector Plugs

1	4-pin Alarm Connector (P102)	2	6-pin Alarm In Connector (P103)	3	7-pin Relay Connector (P104)
Pin	Description	Pin	Description	Pin	Description
1	Alarm Out 1	1	Alarm In 3	1	Alarm Out 4 Normally Open
2	Alarm Out 2	2	Alarm In 4	2	Alarm Out 4 COM
3	Alarm Out 3*	3	Alarm In 5	3	Alarm Out 4 Normally Closed
4	Alarm Ground	4	Alarm In 6	4	Earth Ground
		5	Alarm In 7	5	Analog Alarm 1
		6	Alarm Ground	6	Analog Alarm 2
				7	Ground

* The Alarm Out 3 (on the P102 connector) is the dedicated low pressure alarm for VG4 100 Series AutoDome cameras.

5. To connect supervised alarms and relays, attach the appropriate wires to their terminals on the P104 connector on the Pipe Interface Board (see *Figure 3.11*, above). In addition, see *Section 6 Alarms and Relay Connections, page 96* for more details on wiring alarms and relays.

Note: There is a slot located at the top of the Interface Board to tie the wires to the circuit board with a cable tie.

6. Insert the Pipe Interface Board into the down pipe and fasten the three (3) retaining screws to secure the board to the Dome Cap.

**CAUTION!**

Be careful not to strip the threads when tightening the Pipe Interface Board retaining screws.

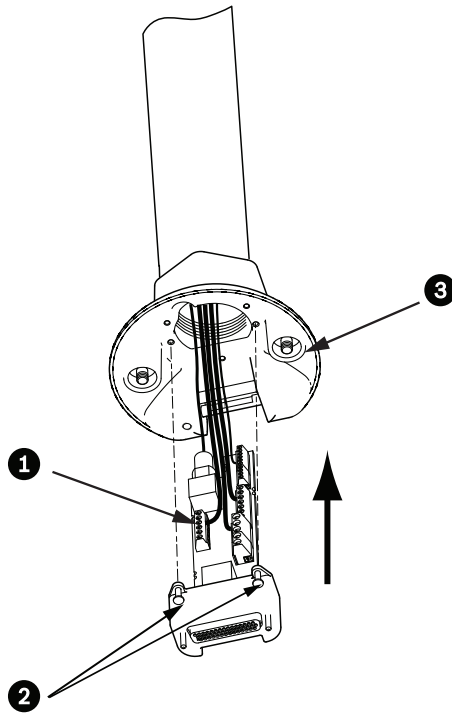

Figure 3.12 Pipe Interface Board to Dome Cap Assembly

1	Interface Board
2	Retaining Screws (3)
3	Pendant Mounting Screws (2)

3.8

Assemble the Pendant in Packing Box

The AutoDome Pendant can be assembled before attaching it to the roof or pipe mount. The Pendant includes a Housing, Camera Module, and Bubble.

1. Open the box containing the Pendant Housing from the top, and remove the two cardboard inserts from the top of the box.
2. Remove the plastic bag from the Pendant Housing, and then place it back into its box.



NOTICE! The Pendant Housing box is designed to hold the housing in-place during the assembly of the Pendant.

3. Remove the Camera Module from its packing box, and remove the protective plastic bag.
4. Align the yellow locking tab on the Camera Module base to the (yellow) label on the CPU board, and gently seat the camera onto its connector.

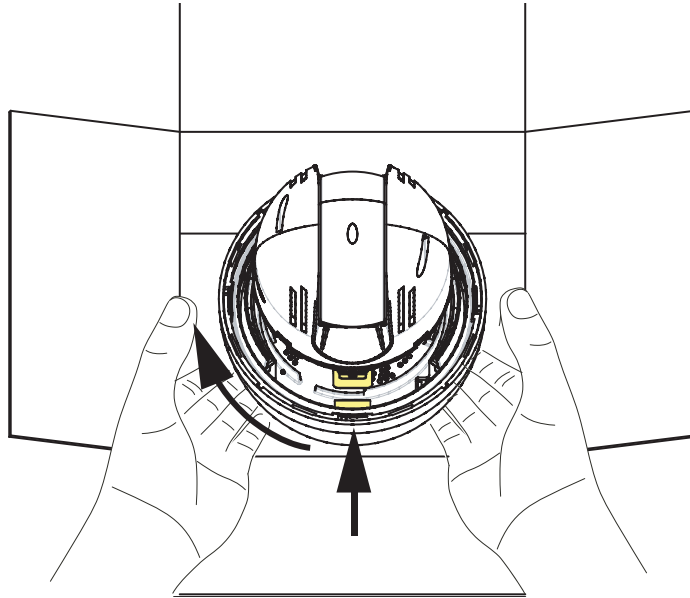

Figure 3.13 Align Lock Tab and Install Camera Module

5. Rotate the base of the Camera Module clockwise (approximately 60 degrees) until the yellow tab locks in place.

Note: The Camera Module must be able to rotate freely when installed in the housing.
6. If you are installing a VG4 Pressurized Environmental Housing, skip to *Section 3.11 Installing the Pressurized Environmental Housing, page 65*. You will attach the bubble to the housing in a later step.

If you are installing a normal VG4 AutoDome, continue with step 7.
7. Remove the bubble from its packing box, and then remove the protective plastic bag.
8. Place the Bubble Assembly over the Camera Module. Using both hands firmly rotate the Bubble Assembly clockwise (approximately 1/8 turn) until it locks in place. (An audible click can be heard when it locks.)

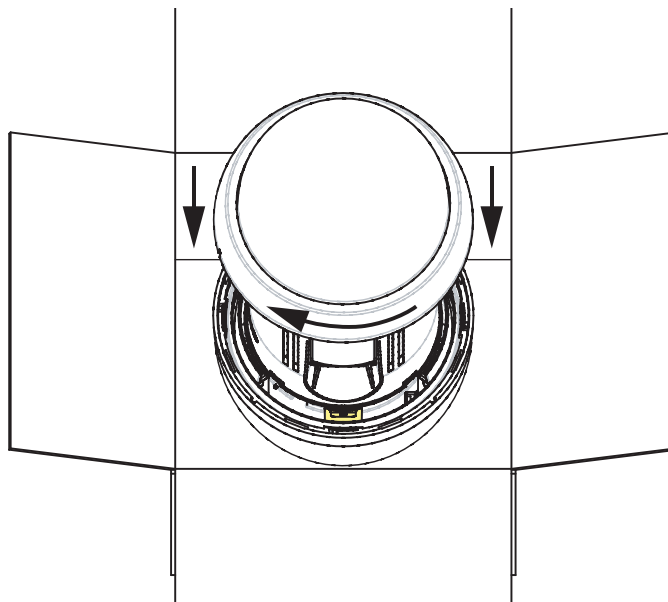

Figure 3.14 Attach the Pendant Bubble Assembly

3.9 Attach Pendant to Pipe and Tighten

1. Before attaching the Pendant, visually inspect the Pendant dome and the Interface Board connectors for any blocked pin holes and bent pins.
2. Tilt the Pendant enough to place its mounting hook on top of the its housing, over the recessed hinge pin of the Dome Cap.

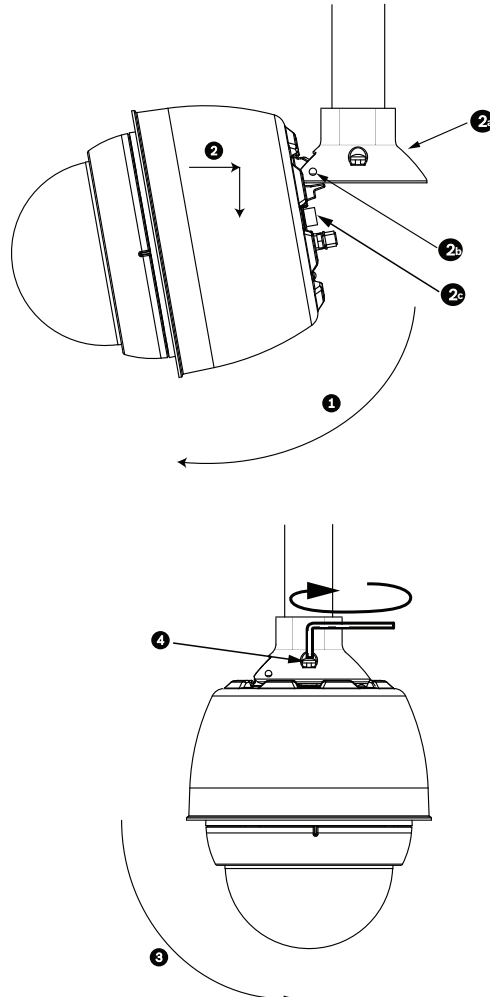

Figure 3.15 Pendant to Roof / Pipe Mount Attachment

1	Tilt Dome.
2	Hook and drop.
2a	Dome Cap
2b	Recessed Hinge Pin
2c	Dome Connector
3	Rotate down to engage dome connector.
4	Tighten the two (2) mounting screws to a minimum torque of 10-12 N-m (90-105 in.-lbs).

3. Drop the Pendant down slightly to engage the dome hook and hinge pin of the Dome Cap, allowing the dome to rotate around the hinge pin.
4. Rotate the dome housing down to a vertical position and gently push upward to engage the connector on top of the dome housing.



CAUTION!

If you feel any resistance when rotating the dome housing or when engaging the connector, stop immediately and start over.

5. Hold the housing firmly in position and alternately tighten the two (2) 5-mm Allen head mounting screws from above to a torque value of 10-12 N-m (90-105 in.-lbs).

**CAUTION!**

You must tighten the two mounting screws to a minimum torque of 10-12 N-m (90-105 in.-lbs) to ensure a proper seal between the arm and the housing.

6. Rotate the arm to swing the AutoDome out from the roof and into position, if installing a Parapet Roof Mount.
7. Tighten the three (3) 10-mm (3/8-inch) stainless steel hex bolts on the bracket to lock the Parapet Arm in position. See *Figure 3.15, Page 62*, for an illustration.

**CAUTION!**

Do not over tighten the bolts. The maximum torque is 34 N-m (25 ft-lb).

3.10

Make Connections in the Power Supply Box

The following procedure references *Figure 3.6, Page 53* to locate the various connectors in the box and to make the proper connections.

1. Attach the earth ground wire to the grounding screw on the left side of the box.
2. Connect the 24 VAC to Dome plug, installed previously, to its mating connector P107 on the right side of the box.
3. Connect the 115/230 VAC, 3-pin Power-in plug, installed previously, to its mating connector P101 on the left side of the box.

3.10.1

Connections for Fiber Optic Models

The following procedure references *Figure 3.6, Page 53*.

1. If installing a Fiber Optic model, attach the incoming ST fiber plug to its mating connector on the Fiber Optic Module in the power box.
2. Connect the video BNC connector from the dome to the Fiber Optic Module BNC connector.



NOTICE! A BNC barrel connector (not supplied) is required to connect the male BNC of the dome to the male BNC connector of the Fiber Optic Module.

3. Connect the six (6) control plugs from the dome, installed previously, to the P106 control I/O connector in the Power Supply Box.

Removing the Pendant Bubble

To service the AutoDome Pendant, use the following procedure to remove the Bubble:

1. Using both hands, apply a firm counterclockwise (looking up at the dome) rotational force on the Pendant Bubble Assembly to set the bubble latch.
2. Insert a small (2 mm) straight blade screw driver into the release opening in the bubble trim-ring to release the lock, and then remove the screwdriver.

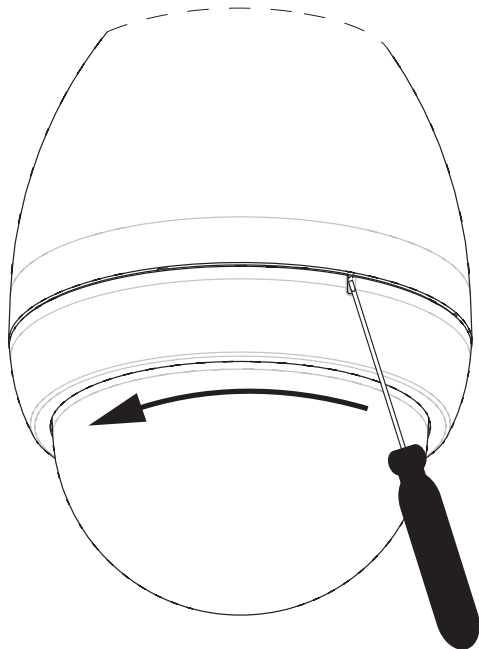

Figure 3.16 Pendant Bubble Release Opening

3. Firmly rotate the bubble counterclockwise approximately 20 degrees until the bubble assembly releases from the Pendant Housing.

3.11 Installing the Pressurized Environmental Housing

The VG4 Pressurized Environmental Housing provides maximum protection for CCTV cameras and lenses. The charge of dry nitrogen inside the housing eliminates the effects of moisture, dust, insects, and corrosive exhaust fumes.

This section provides the details and instructions for mounting the pendant to a parapet (roof) mount or to a pipe mount, calibrating the pressure sensor, and pressurizing the dome with dry nitrogen.

Note: If you are installing a normal VG4 AutoDome (not a pressurized dome), skip the remainder of this chapter.

3.11.1 Important Installation Safeguards

- Always use safety goggles when servicing the unit.
- Never use an unregulated gas supply to pressurize the enclosure. The valve should be regulated with a maximum of 86.18 kPa (12.5 psi) output.
- PRESSURIZE USING DRY NITROGEN ONLY!



CAUTION!

Be sure to periodically examine the unit and its supporting structure. If the dome shows any signs of wear, such as stress cracking, it should be replaced immediately.

3.11.2 VG4 Pressurized Environmental Housing

The VG4 Pressurized Environmental Housing differs from normal VG4 housings because of the addition of a Schrader fill valve, located on the back side of the housing, and a pressure relief valve, located on the top of the housing cap.

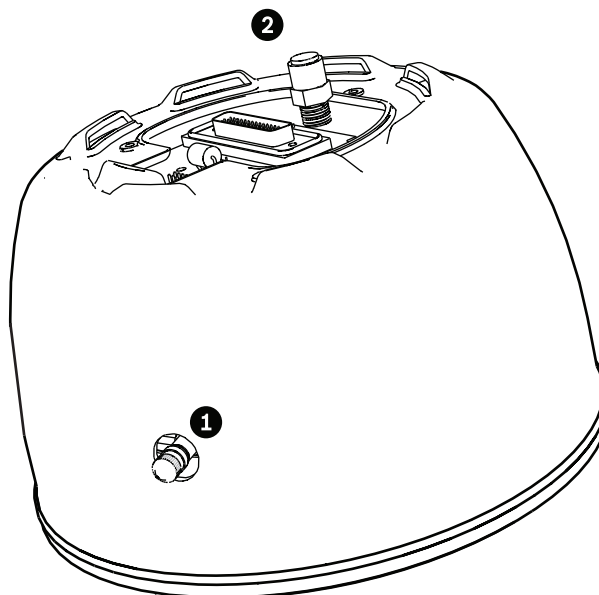

Figure 3.17 VG4 Pressurized Environmental Housing

1	Schrader Fill Valve
2	Pressure Relief Valve

3.11.3

Required Equipment

To pressurize the housing, you need the following:

- **A tank of dry nitrogen**

Nitrogen is a readily available gas; check your local yellow pages for a medical or industrial gas provider. If the tank is to be carried from location to location, a size of 1 cubic meter (40 cubic feet) is recommended. This tank size should be enough to refill 30 individual housings. Tanks of dry nitrogen can be kept for several years



CAUTION!

Handle the tanks with care. Although nitrogen is an inert gas, the tank is highly pressurized and if the valve or regulator is damaged, the tank could be dangerous.

- **A regulator on the tank**

A regulator for the tank is required, even though the tank is fitted with a standard 580 fitting. Recommended regulators for the tank are: Harris #9296-15-580 or #425-15-580. For local distribution, contact Harris at 800-241-0804.

- **A hose with an air chuck to connect the regulator to the housing's fill valve**

The Schrader fill valve, also called a dill valve, is similar to the air intake valve on car tires or bicycle tires. To connect the regulator to the purge valve on the housing, you need a hose with a 1/4-inch barb on one end and an air chuck on the other. The barb connects to the regulator and the air chuck connects to the Schrader valve. You may obtain these hoses at local auto parts stores.

- **A T25 pin-in Torx driver**

This tool is required to tighten the eight (8) captive screws that secure the bubble to the housing. A small pin-in Torx tool comes with the VG4 Pressurized Environmental Housing module, but you may prefer to use a larger driver.

3.11.4 Attaching the Housing to the Pipe

1. Before attaching the housing, visually inspect the dome and the Interface Board connectors for any blocked pin holes and bent pins.
2. Tilt the housing enough to place its mounting hook on top of the its housing, over the recessed hinge pin of the Dome Cap.

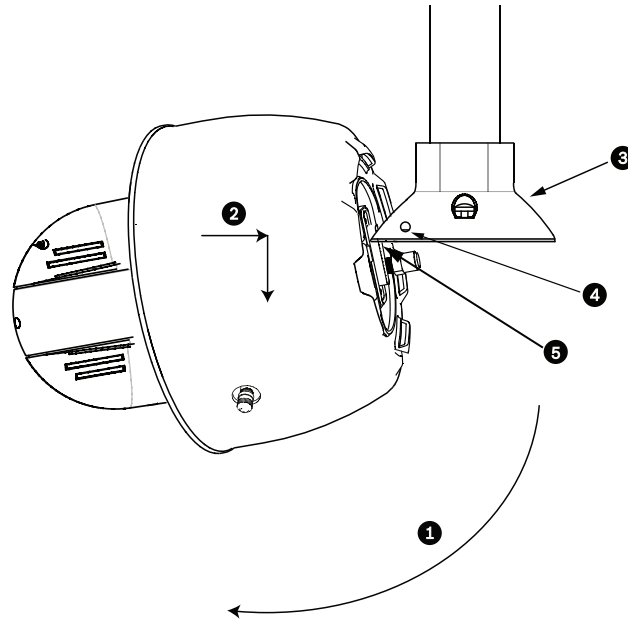

Figure 3.18 Attach AutoDome to Pipe

1	Tilt Dome
2	Hook and drop
3	Dome Cap
4	Recessed Hinge Pin
5	Dome Connector

3. Drop the housing down slightly to engage the dome hook and hinge pin of the Dome Cap, allowing the dome to rotate around the hinge pin.
4. Rotate the housing down to a vertical position and gently push upward to engage the connector on top of the dome housing.



CAUTION!

If you feel any resistance when rotating the dome housing or when engaging the connector, stop immediately and start over.

5. Hold the housing in position while tightening the two (2) 5-mm Allen head mounting screws on top of the housing to **10-12 N-m (90-105 in.-lbs)**.

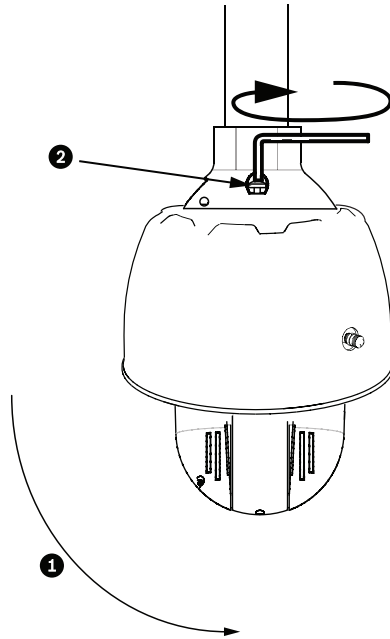

Figure 3.19 Tighten Pendant Connection

1	Rotate down to engage dome connector.
2	Tighten the two (2) mounting screws to a minimum torque of 10-12 N-m (90-105 in.-lbs).



CAUTION!

You must tighten the two mounting screws to a minimum torque of 10-12 N-m (90-105 in.-lbs) to ensure a proper seal between the arm and the housing.

3.11.5

Make Connections in the Power Supply Box

The following procedure references *Figure 3.6, Page 53* to locate the various connectors in the box and to make the proper connections.

1. Attach the earth ground wire to the grounding screw on the left side of the box.
2. Connect the 24 VAC to Dome plug, installed previously, to its mating connector P107 on the right side of the box.
3. Connect the 115/230 VAC, 3-pin Power-In plug, installed previously, to its mating connector P101 on the left side of the box.

Connections for Fiber Optic Models

The following procedure references *Figure 3.6, Page 53*.

1. If installing a Fiber Optic model, attach the incoming ST fiber plug to its mating connector on the Fiber Optic Module in the power box.
2. Connect the video BNC connector from the dome to the Fiber Optic Module BNC connector.



NOTICE! A BNC barrel connector (not supplied) is required to connect the male BNC of the dome to the male BNC connector of the Fiber Optic Module.

3. Connect the six (6) control plugs from the dome, installed previously, to the P106 control I/O connector in the Power Supply Box.

3.11.6 Calibrating the Pressure Sensor

The VG4 Pressurized Environmental Housing features an internal low-pressure sensor alarm which must be calibrated to the local atmospheric pressure. The heater/blower/pressure sensor power must be connected to do calibration.

You must perform the calibration procedure within four (4) minutes of powering up the VG4 unit or the sensor will not store the calibration data. If you should miss this calibration period, power off the unit and restart the procedure.

Once the sensor is calibrated no further adjustment is necessary. You may recalibrate the unit, however, anytime that power is shut off to the VG4 unit.

The procedure is as follows:

1. Apply power to the VG4 unit. The green LED, located at the left side of the camera module, illuminates and remains constant.
2. After approximately 30 seconds the LED begins to blink, indicating that the VG4 unit is ready to be calibrated.
3. Using a thin screwdriver press and hold the red calibration switch, located on the opposite side of the LED.

Once the sensor is calibrated and the data is permanently stored, the LED shuts off and you can release the calibration switch.

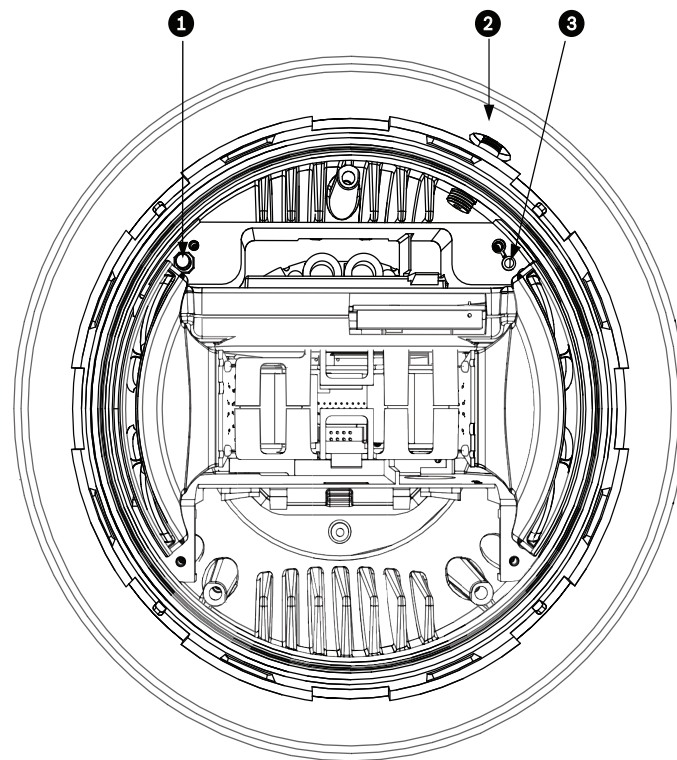

Figure 3.20 Location of the Calibration Switch

1	Calibration Switch
2	Schrader Fill Valve
3	LED

4. Turn the power off to the VG4 unit.

3.11.7

Attaching the Bubble to the Housing

1. Remove the bubble from the box and then remove the bubble from the protective plastic bag.
2. Disengage the four tabs from the white trim skirt ring that surrounds the bubble. Then, move the trim skirt ring towards the bubble opening to remove.

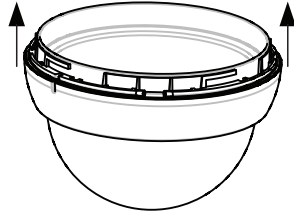

Figure 3.21 Bubble with Trim Skirt Ring

3. Discard the trim skirt ring. It is not needed for the VG4 Pressurized Environmental Housing installation.
4. Clean the inside of the bubble. Refer to *Section 7 Bubble Handling and Cleaning, page 100*, for cleaning instructions and for recommended products.
5. Clean the groove inside the rubber bubble gasket with pressurized air to remove debris. Then, using alcohol, clean the groove to remove oil and grease.
6. Insert the sealing edge of the bubble into the groove in the rubber bubble gasket.
7. Place the bubble support ring over the bubble and align the eight (8) captive screws with the threaded inserts on the plastic gasket ring.

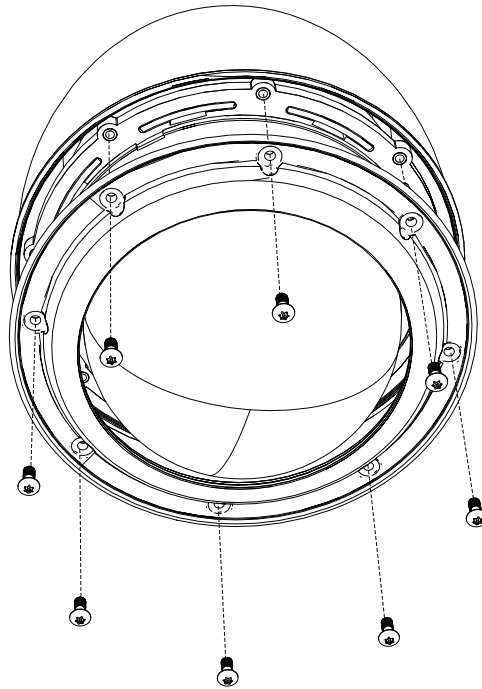

Figure 3.22 Attach Bubble Support Ring

- Loosely tighten the captive screws with the T25 pin-in Torx tool using a diametrically opposed tightening pattern, until the gap between the bubble support ring and the housing closes.

Start tightening screw 1, then tighten screw 2. Next, tighten screw 3 and continue to screw 4. Continue tightening the screws in this pattern.

Note: Make sure not to overtighten the screws.

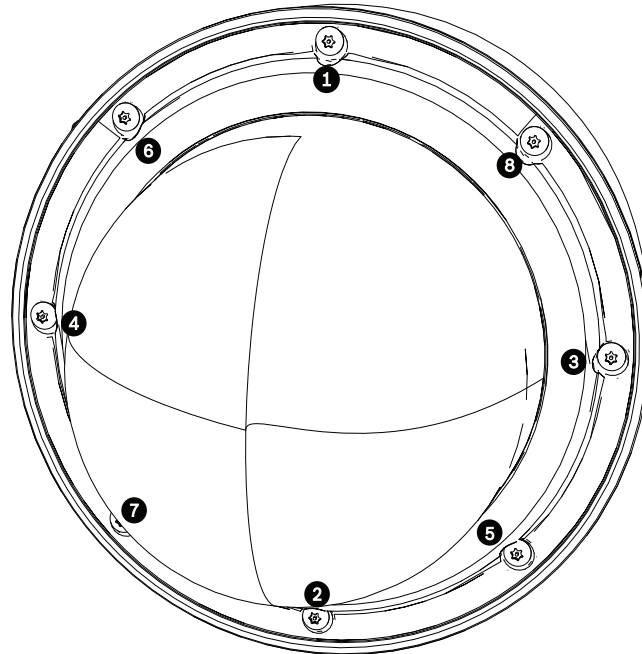

Figure 3.23 Bubble Support Ring Tightening Pattern

- Tighten the screws again, using the same diametrical pattern, to a torque of 0.90 N-m (8 in.-lbs). Use a dial-indicator torque screwdriver to check the torque.
- Begin a second round of tightening, using the same diametrical pattern, until the screws reach a torque of 1.58 N-m (14 in.-lbs).
- Continue tightening the screws, using the same diametrical pattern, to reach a torque of 2.26 N-m (20 in.-lbs).
- Finish tightening the screws, using the same diametrical pattern, to reach a final torque of 2.71 N-m (24 in.-lbs).
- Perform a final check, using the same diametrical pattern, of each screw. Adjust any screw that is below 2.71 N-m (24 in.-lbs) of torque.

3.11.8 Pressurizing the Housing

The VG4 Pressurized Environmental Housing can maintain a maximum internal pressure of 75.84 kPa (11 psi) \pm 5%. Above 75.84 kPa (11 psi), the pressure relief valve cracks and then seats at a pressure of 65.50– 68.95 kPa (9.5–10 psi).

Follow these steps to pressurize the housing:

1. Set the gauge on the regulator to 86.18 kPa (12.5 psi).
2. Place the air chuck on the Schrader fill valve, just as you would on a tire, and press down to begin filling the housing. The dome should reach maximum pressure in under ten seconds.

Excess air should vent from the pressure relief valve after the maximum internal pressure of 75.84 kPa (11 psi) is reached.

3. Remove the air chuck from the Schrader fill valve.
4. Attach a pressure gauge to the Schrader fill valve. Ensure that the pressure inside the housing is between 62.05 kPa (9 psi) and 79.98 kPa (11.6 psi).
5. After you verify the pressure, reconnect the air chuck and purge the remaining air inside the housing for five (5) minutes.

3.11.9 Servicing the Pressurized Environmental Housing installation

To service the AutoDome Pendant, use the following procedure to remove the Bubble:

1. Purge the nitrogen from inside the Pressurized Environmental Housing and bubble.
2. Loosen, but do not fully remove, the eight (8) captive screws using a T25 pin-in Torx driver from the bubble support ring.
3. Support the bubble with your hand to ensure that it does not fall as you fully remove the captive screws using an alternating pattern.
4. Remove the bubble and the bubble support ring.

4 Installing the In-Ceiling Mount

4.1 Unpacking

This equipment should be unpacked and handled with care. If an item appears to have been damaged in shipment, notify the shipper immediately.

Verify that all the parts listed in the product's Parts List below are included. If any items are missing, notify your Bosch Security Systems Sales or Customer Service Representative. See Section 1.5 for Customer Support and Service contact information.

The original packing carton is the safest container in which to transport the unit and must be used if returning the unit for service. Save it for possible future use.

4.1.1 Parts List

The following table lists the parts included with the In-ceiling mount packages.

In-ceiling Mount Kit		
Quantity	Item	Part Number
1	Interface Box	VG4-S-BIM
1	In-ceiling Housing (COMMS and CPU modules installed)	F01U010500
1	Camera Module	VG4-MCAM-XXX
1	Bracket Assembly	LTC 9349MK
1	Clear Bubble with white and black trim rings, or Tinted Bubble with white and black trim rings	VG4-SBUB-CCL VG4-SBUB-CTI

The following figure depicts the parts for the in-ceiling mount.

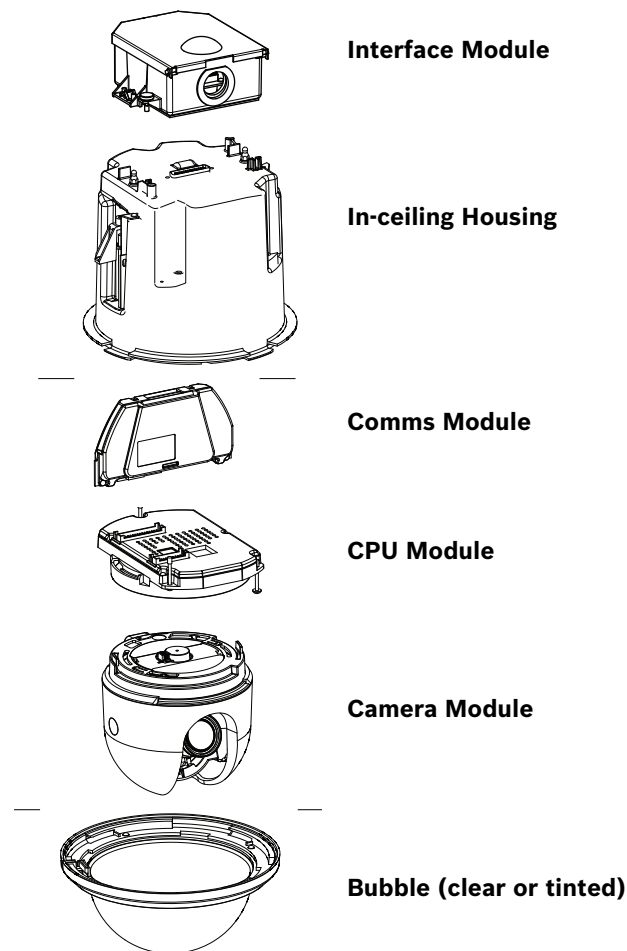

4.1.2

Description

This chapter details how to install the AutoDome in an In-Ceiling Mount. The In-Ceiling AutoDome system is suitable for use in environmental air spaces. See Chapter 2 for instructions to install an AutoDome Pendant Arm to a Wall, Corner, or Mast (or pole), or see Chapter 3 for instructions to install a Parapet (Roof) or Pipe Mount AutoDome system.

4.1.3

Tools Required

- Straight slot screwdrivers ~ 2.5 mm (0.1 inch) – 3.1 mm (1/8 inch)
- No. 2 Phillips screwdriver
- Appropriate tool for cutting a hole in drywall or ceiling tile
- Pliers

4.2 Pre-installation Check List

1. Determine the location and distance for the power supply box based on its voltage and current consumption. See *Section 5 Cable and Wire Standards, page 85* for specifications.
2. Install all rough wiring including: power, control, video, alarms I/O, relay I/O, and fiber optic cabling.



WARNING!

24 VAC Class 2 power supply only.

3. A minimum of 216-mm (8 1/2-inch) of air space above the ceiling is required to install the In-ceiling Mount.
4. If this AutoDome installation utilizes the AutoTracker feature, refer to *Section A Installation Notes for AutoTracker, page 101*, before mounting the AutoDome.

4.3 Dimensions

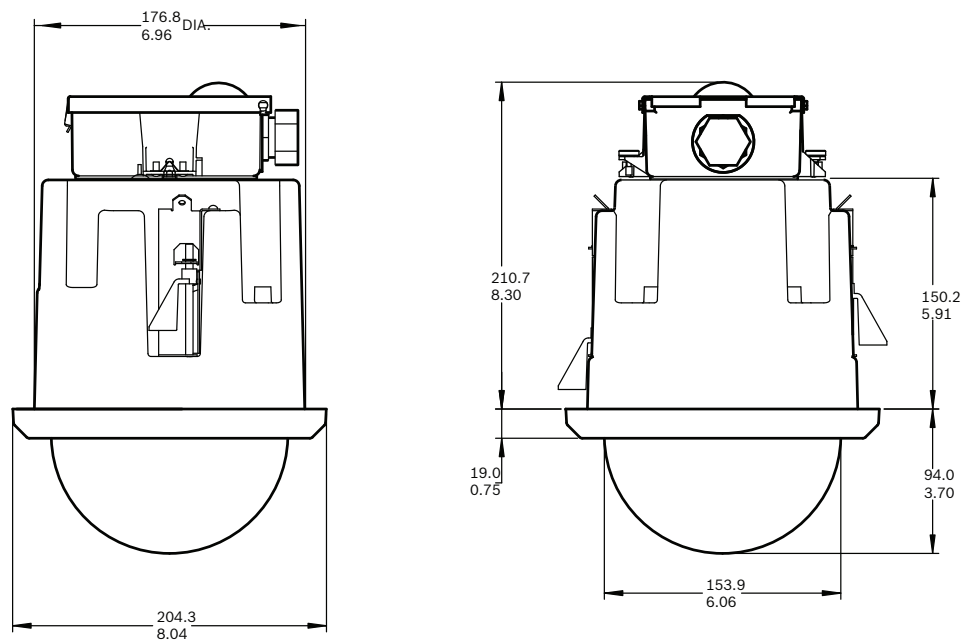

$\frac{\text{mm}}{\text{inches}}$

Figure 4.1 In-ceiling Dimensional Outline

4.4 Prepare Drywall Ceiling for Installation

1. Choose the desired location to mount the dome.
2. Use the bracket Base Plate as a template or cut a 178 mm (7 in.) hole in the ceiling with a drywall utility saw or Jig Saw. Proceed to *Section 4.6 Wire the Interface Box, page 78*, for further instructions.

4.5 Prepare Suspension Ceiling for Installation

1. Choose the desired location to mount the dome, and remove an adjacent ceiling tile.
2. Loosen the four (4) securing screws, located in the corners of the Bracket Assembly, enough to hold the suspension bars but still allowing adjustment during installation.
3. Place the Bracket Assembly over the ceiling tile, which is used to mount the In-Ceiling AutoDome. Then snap the Bar Clips of the bracket to the ceiling rails.

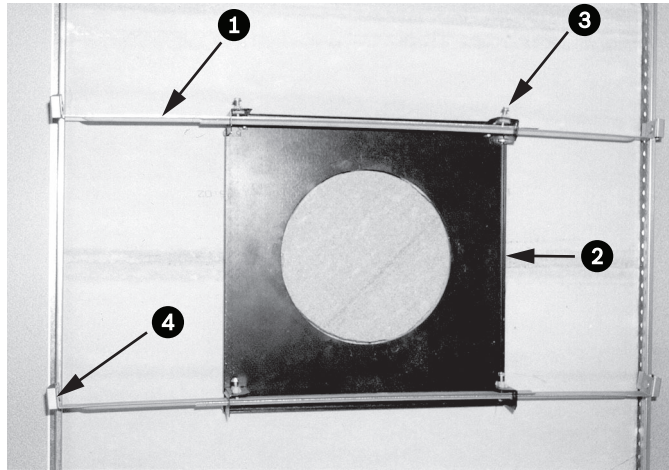

Figure 4.2 Suspension Ceiling Bracket (Top View)

1	Suspension Bars	3	Securing Screw (4)
2	Base Plate	4	Bar Clips

4. Use the bracket Base Plate as a template or cut a 178 mm (7 in.) hole in the center of the ceiling tile with a drywall utility saw or Jig Saw.

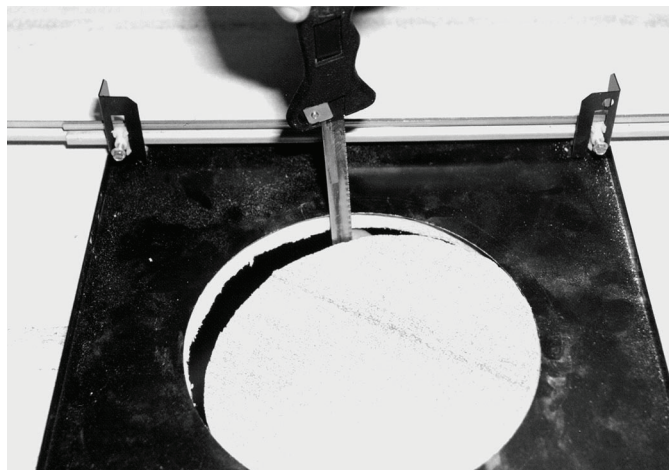

Figure 4.3 Cut Hole in Ceiling Tile

5. Tighten the four (4) securing screws to the Bracket Assembly.

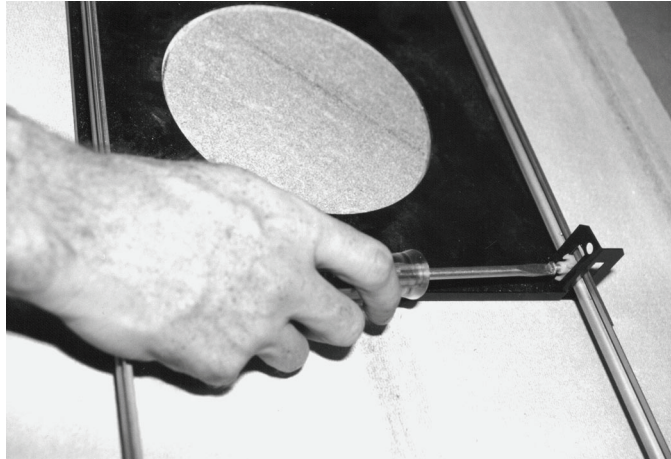

Figure 4.4 Tighten Bracket Securing Screw

6. Secure the Bracket Assembly to an overhead securing point with a safety wire.

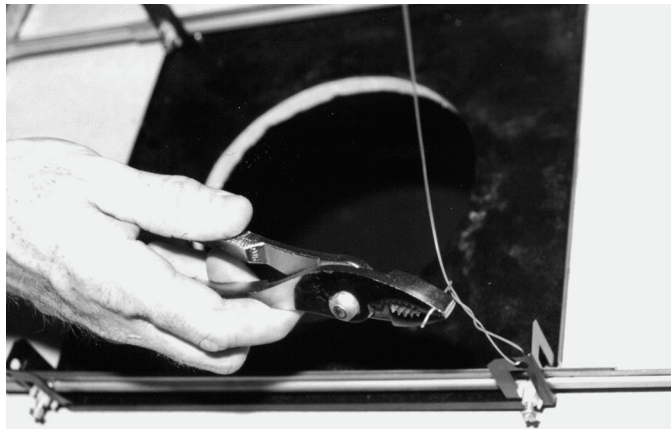

Figure 4.5 Secure Bracket Assembly

4.6 Wire the Interface Box

The Interface Box can be wired through the top or side. Use the supplied rubber plug to seal the hole which will not be used to route wires.

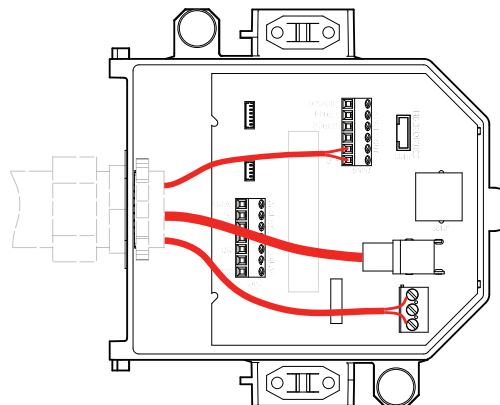

Figure 4.6 Interface Box Connections

After routing all video, control, power, and alarm wires:

1. Attach a 3/4-inch NPS (20-mm) conduit fitting to the hole in which you bring in the wires. Be sure to thread the inside nut to the conduit fitting.
2. Route the video, control, power, and alarm wires through the conduit fitting and into the Interface Box.
3. Cut and trim the wires allowing for sufficient slack to their respective terminals in the box.



NOTICE! If installing the dome to a drywall ceiling, allow enough wire to make the connections in the Interface Box below the ceiling. See *Figure 4.6, Page 78*, for connector locations and *Table 4.1, Page 80*, for wire connections.

4. Attach the video and control data in/out wires to their respective terminals in the Interface Box. See *Table 4.1, Page 80*, for terminal connections.
5. If using UTP for video or Ethernet, you must attach an RJ45 connector plug to the incoming UTP cable and connect it to its matting connector J101 in the Interface Box. See *Section 5 Cable and Wire Standards, page 85* for specifications.
6. Connect the 24 VAC power wires to the P101 connector in the Interface Box.

- To connect alarm inputs and outputs, attach the supplied 6-pin Alarms In and the 4-pin Alarms Out connector plugs with flying leads to the appropriate alarm wires. Then connect the plugs to their mating connectors P103 and P102 in the Interface Box.

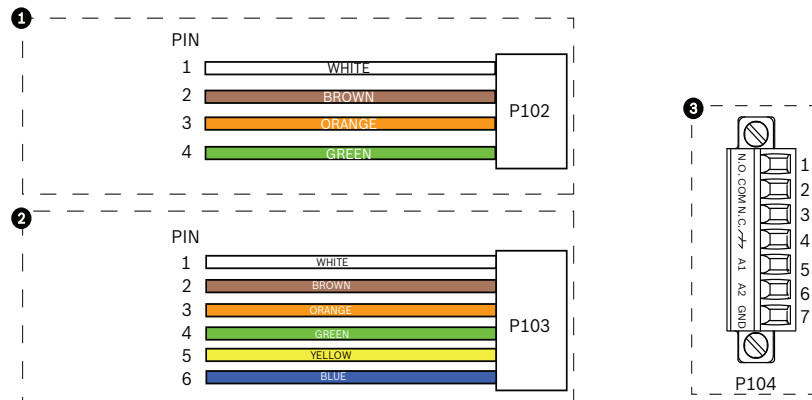

Figure 4.7 Alarm and Relay Connector Plugs

1	4-pin Alarm Connector (P102)	2*	6-pin Alarm In Connector (P103)	3	7-pin Relay Connector (P104)
Pin	Description	Pin	Description	Pin	Description
1	Alarm Out 1	1	Alarm In 3	1	Normally Open
2	Alarm Out 2	2	Alarm In 4	2	COM
3	Alarm Out 3	3	Alarm In 5	3	Normally Closed
4	Alarm Ground	4	Alarm In 6	4	Earth Ground
		5	Alarm In 7	5	Analog Alarm 1
		6	Alarm Ground	6	Analog Alarm 2
* Low Voltage TTL (3.3V) can also be used.				7	Ground

- To connect supervised alarms and relays, attach the appropriate wires to their terminals on the P104 connector on the Pipe Interface Board. See *Section 6 Alarms and Relay Connections*, page 96 for more details on wiring alarms.

4.6.1 Interface Box Connections

The following figure is a detailed illustration of the In-ceiling Interface box.

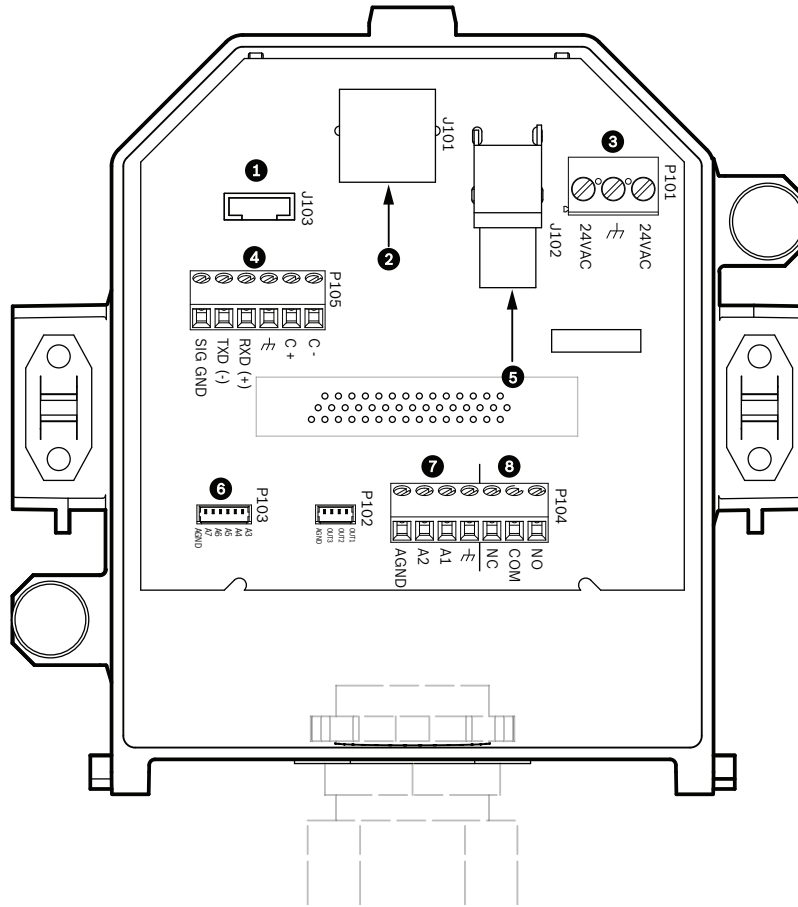

Figure 4.8 In-ceiling Interface Box

1	Fiber Optics	5	Coax Video
2	Ethernet or UTP Video	6	Alarm In
3	Dome Power	7	Analog In
4	Data In/Out	8	Relay

The following table summarizes the pin connectors and their function:

No.	Connector	Pin 1	Pin 2	Pin 3	Pin 4	Pin 5	Pin 6	Pin 7
P103	Alarms In	Alarm 3	Alarm 4	Alarm 5	Alarm 6	Alarm 7	AGND	
P102	Alarms Out	Alarm 1	Alarm 2	Alarm 3	GND			
P104	Analog Relay	Relay N.O.	Relay COM	Relay N.C.	Earth	Alarm 1	Alarm 2	Ground
P105	Data In/Out	C- (BiPhase)	C+ (BiPhase)	Earth Ground	RXD (+) (RS-232/485)	TXD (-) (RS-232/485)	Signal Ground	
P101	24 VAC	Line	Earth	Neutral				
J102	Video BNC	Connector Input						
J101	UTP/Ethernet	Connector Input						

Table 4.1 Interface Box Wire Terminals



WARNING!

24 VAC Class 2 power supply only.

4.7 Attach Housing to the Interface Box

The In-Ceiling Housing is attached to the Interface Box and secured by two (2) thumbscrews.

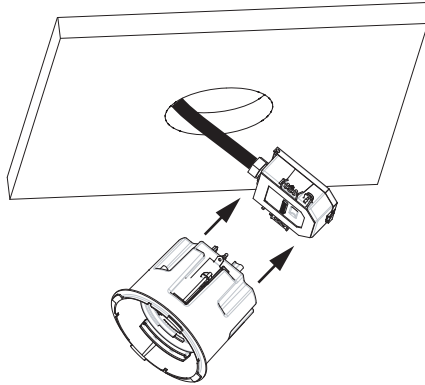

Figure 4.9 Attach Housing to Interface Box

1. Insert the In-ceiling housing through the hole in the ceiling to verify that the edge of the hole support the unit. Then remove the housing from the hole.
2. Align the ball studs of the In-Ceiling Housing to the Stud Retainers on Interface Box and attach.
3. Tighten the two (2) Thumbscrews to secure the Interface Box to the housing.

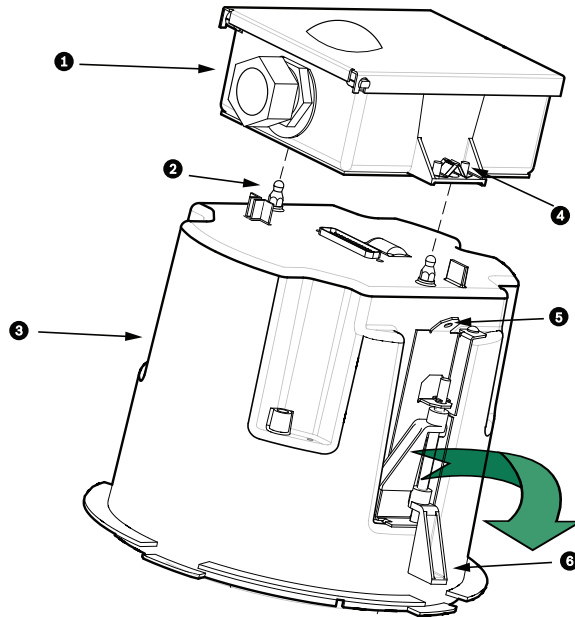

Figure 4.10 In-Ceiling Housing and Interface Box

1	Interface Box	4	Thumb Screw
2	Ball Stud	5	Tether Point
3	In-ceiling Housing	6	Ceiling Clamp



CAUTION!

The In-ceiling dome is provided with tether points on each side of the housing. To prevent injury, attach a safety wire from a secure anchor point above the ceiling to a tether point on the dome housing, see *Figure 4.11, Page 82*, below for an illustration of this process.

4.8 Secure Housing to Ceiling

The In-ceiling Housing is secured to the ceiling by two (2) screw clamps.

1. Insert the In-ceiling Mount Assembly through the hole in the ceiling.
2. Tighten both clamps using a #2 Phillips screwdriver, to secure the housing to the ceiling.

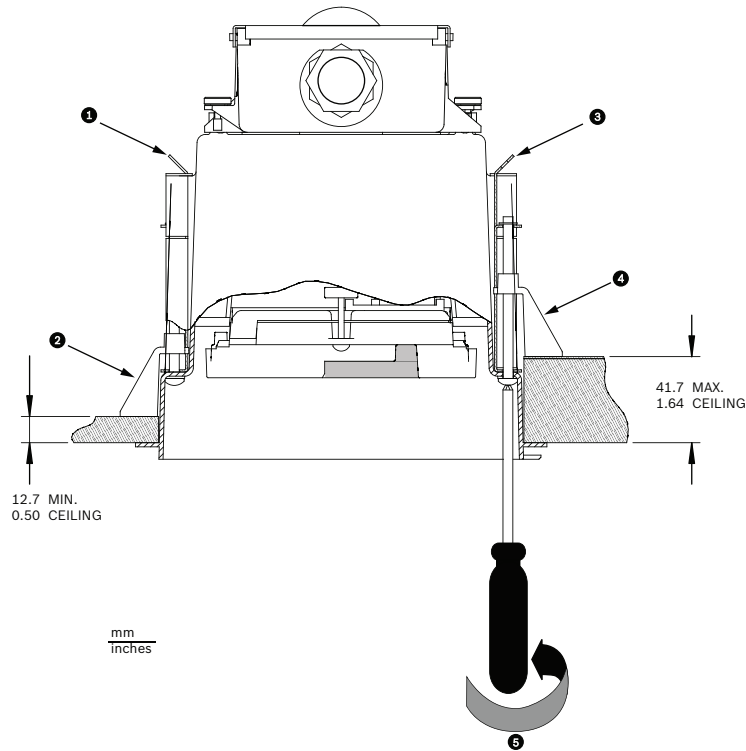

Figure 4.11 Secure Dome to Ceiling

1	Tether Point	4	Ceiling Clamp
2	Ceiling Clamp	5	Rotate Clockwise to Engage Clamp
3	Tether Point		



CAUTION!

Over torquing the Ceiling Clamps can damage the clamp or ceiling. Only tighten the clamp until it contacts the ceiling and you start to feel some resistance. If using a power screwdriver, set the torque level to the lowest setting.

4.9 Align and Install Camera Module

The Camera Module connector attaches to the In-Ceiling Housing CPU board.

1. Align the yellow locking tab on the base of the Camera Module to the yellow label on the CPU Module and press the camera base onto its connector.
2. Then rotate the camera clockwise (approximately 60 degrees) until it locks in position.

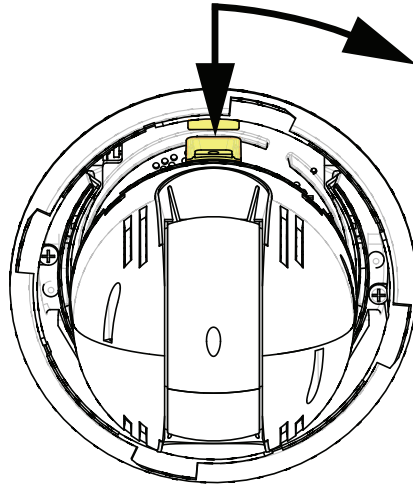

Figure 4.12 Install Camera Module and Bubble

4.10 Attach Bubble

The Dome Bubble/trim assembly attaches to the In-Ceiling Housing.

1. Place the bubble over the Camera Module, and align it until it settles.
2. Rotate the bubble clockwise until it locks in position. See *Figure 4.12, Page 83*.



NOTICE! The dome bubble comes assembled with a white trim ring. An optional black trim ring is supplied separately. To replace the white trim ring, remove the four (4) Phillips head screws from the inner ring and remove the white trim ring. Then place the black trim ring over the inner ring, and replace and tighten the four (4) screws.

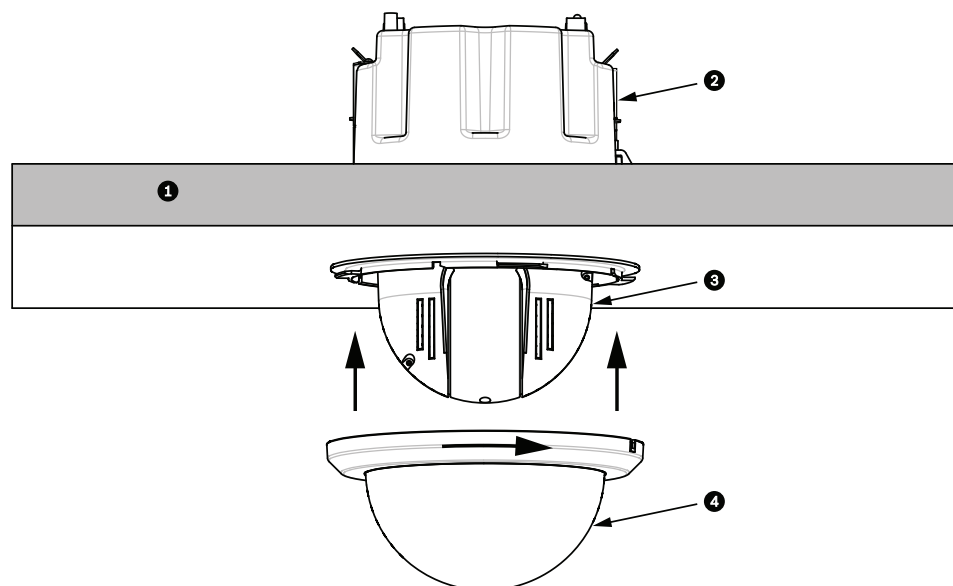

Figure 4.13 In-Ceiling Bubble

1	In-ceiling Housing	3	Camera Module
2	Ceiling	4	Bubble

Bubble Removal

To service the In-Ceiling AutoDome, use the following procedure to remove the Bubble:

1. Loosen the lockscrew (item 1 in the illustration below) in the trim ring using a P1 or smaller Phillips screwdriver until the bubble can rotate freely.
2. Then rotate the bubble counterclockwise approximately 1/4 turn until it releases from the In-Ceiling Housing. See the figure below for an illustration.

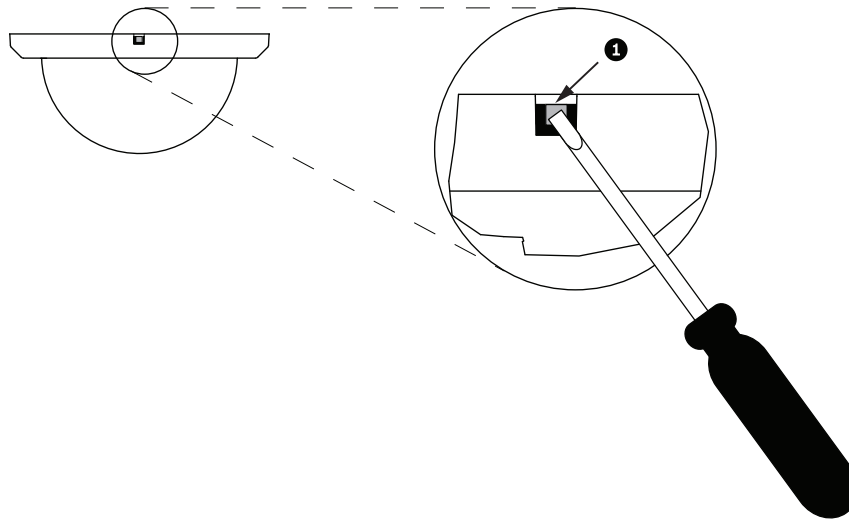

Figure 4.14 Bubble Release Screw

5 Cable and Wire Standards

5.1 Power

115/230 VAC	
Copper Wire	To comply with local codes.

5.2 Wire Distance Guide for Pendant

24 V to AutoDome				
INDOOR ANALOG				
100 Series	VA / Watts	14 AWG (2.5 mm)	16 AWG (1.5 mm)	18 AWG (1.0 mm)
200, 300 Series	14 / 7.5	248 m (813 ft)	156 m (512 ft)	98 m (322 ft)
500 Series	18 / 10	193 m (632 ft)	121 m (398 ft)	76 m (250 ft)
	27 / 15	129 m (422 ft)	81 m (265 ft)	51 m (167 ft)
INDOOR ETHERNET				
100 Series	VA / Watts	14 AWG (2.5 mm)	16 AWG (1.5 mm)	18 AWG (1.0 mm)
200, 300 Series	21 / 11.5	165 m (542 ft)	104 m (341 ft)	65 m (215 ft)
500 Series	25 / 14	139 m (455 ft)	87 m (287 ft)	55 m (180 ft)
	35 / 19	99 m (325 ft)	62 m (205 ft)	39 m (129 ft)
OUTDOOR ANALOG¹				
100 Series	VA / Watts	14 AWG (2.5 mm)	16 AWG (1.5 mm)	18 AWG (1.0 mm)
200, 300 Series	47 / 43.5	74 m (242 ft)	46 m (152 ft)	29 m (96 ft)
500 Series	50 / 46	69 m (228 ft)	44 m (143 ft)	27 m (90 ft)
	55 / 51	63 m (207 ft)	40 m (130 ft)	25 m (82 ft)
OUTDOOR ETHERNET¹				
100 Series	VA / Watts	14 AWG (2.5 mm)	16 AWG (1.5 mm)	18 AWG (1.0 mm)
200, 300 Series	52 / 47.5	67 m (219 ft)	42 m (138 ft)	26 m (87 ft)
500 Series	54 / 50	64 m (211 ft)	40 m (133 ft)	25 m (83 ft)
	60 / 55	58 m (190 ft)	36 m (119 ft)	23 m (75 ft)

1. Standard heater module

Table 5.1 Maximum Wire Distances from Power Supply to AutoDome Pendant

5.3 Video and Control Cables

Coaxial Cable

Coaxial cable terminated with BNC connectors is the most common method for transmitting composite video. Bilinx control data can also be sent over the same cable.

Bilinx is a Bosch 2-way communication protocol that allows remote control, configuration, and updates over a video coax cable. Bilinx is available on all AutoDomes, except Ethernet models, using the standard communications module.

AutoDome Series 300 and 500i feature cable compensation or “Pre-Comp,” which extends the range of video from the head end.

Cable Compensation	Maximum Distances		
	Video Only		Bilinx Control
Cable Type	Pre-comp OFF	Pre-comp ON	Pre-comp ON or OFF
RG-59/U	300 m (1000 ft)	600 m (2000 ft)	300 m (1000 ft)
RG-6/U	450 m (1500 ft)	900 m (3000 ft)	450 m (1500 ft)
RG-11/U	600 m (2000 ft)	1200 m (4000 ft)	600 m (2000 ft)

Cable Compensation	Maximum Distances	
	Video Only	Bilinx Control
Size	O.D. between 4.6 mm (0.181 in.) and 7.9 mm (0.312 in.)	
Shield	Copper braid: 95%	
Central Conductor	Standard copper center	
Terminal Connector	BNC	



WARNING!

Cable compensation (Pre-Comp) does not extend the range of Bilinx control. Pre-Comp is not available to AutoDomes with an IP module.

UTP

Unshielded twisted pair (UTP) cable terminated with RJ45 male connectors are used to transmit composite video using pins 1(+) and 2(-). Typically, a Coax to UTP cable converter is required at the head-end of the system.

Bilinx control data can also be sent over the same two video wires (1 & 2). Bilinx is a Bosch 2-way communication protocol that allows remote control, configuration and updates over a passive UTP cable.

AutoDome Series 300 and 500 feature cable compensation or “Pre-Comp,” which extends the normal range of control from the head end.

Cable Compensation	Maximum Distance	
		Pre-comp OFF
Cable Type	229 m (750 ft)	450 m (1500 ft)
Terminal Connector	RJ45	
Requirement	Coax to UTP Converter	

The following figure illustrates the connections necessary to transmit video and control over a UTP cable.

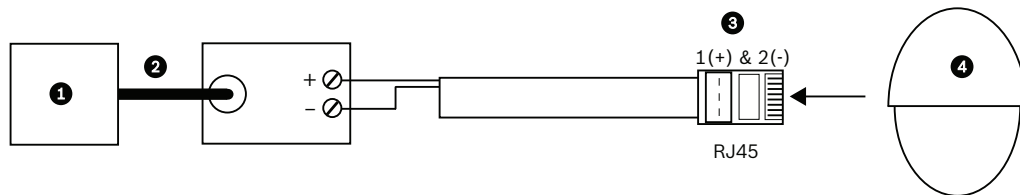

Figure 5.1 Video and Control over UTP

1	Head End Video	3	Pins
2	Coax	4	AutoDome

Ethernet

AutoDome Ethernet models are connected to a 10/100 Base-T network either directly or via a hub. Both video and control are transmitted over a standard TCP/IP network using the built-in web server.

Cable Type	UTP CAT-5
Maximum Distance	100 m (328 ft)
Bandwidth	10/100 Base-T
Terminal Connector	RJ45

**WARNING!**

Do not connect the RJ45 connector unless using UTP video or Ethernet.

Multi-mode Fiber Optic

Fiber Optic models transmit both video and Biphase control over an analog singlemode or multimode fiber. A full or half duplex, multimode IP media converter fiber optic module is also available.

Multimode	
Fiber Type	50/125 μm , 62.5/125 μm , low loss multimode glass fiber
Maximum Distance	4 km (2.5 miles)
Minimum Bandwidth	20 MHz (Video - 850 nm / Control - 1300 nm)
Requirement	Bosch LTC 4629 Fiber Receiver at controller end of system
Terminal Connector	ST

Singlemode	
Fiber Type	9/125 μm , low loss single glass fiber
Maximum Distance	69 km (43 miles)
Minimum Bandwidth	20 MHz (Video - 1310 nm /Control - 1550 nm)
Requirement	Single mode fiber receiver at controller end of system
Terminal Connector	ST

Fiber Optic Ethernet Media Converter

The fiber optic media converter is designed to transmit 10/100 Mbps Ethernet signals over fiber optic cable using 10/100 Mbps Small Form-factor Pluggable (SFP) modules. The SFP modules are available as multi-mode fiber (MMF) or single-mode fiber (SMF) models with a single SC connector or dual-fiber with an LC connector. Refer to the *VG4-SFPSCKT Fiber Optic Media Converter Installation Guide*.

Ethernet Media Converter	
Data Interface	Ethernet
Data Rate	10/100 Mbps IEEE 802.3 Compliant Full Duplex or Half Duplex Electrical Port Full Duplex Optical Port
Fiber Type, MMF	50/125 μ m MMF. For 50/125 μ m fiber, subtract 4 dB from the specified optical budget value. Must meet or exceed fiber standard ITU-T G.651.
Fiber Type, SMF	8–10/125 μ m SMF. Must meet or exceed fiber standard ITU-T G.652.
Maximum Distance	60 km (37.3 miles)
Requirement	Media converter receiver (CNFE2MC/IN) at controller end of system
Terminal Connection	Duplex LC or Single SC

5.4

Control-only Cables

Biphase (Shielded 2-wire, half-duplex, multi-drop, 5000 ft. cable limit)

Biphase is the standard Bosch protocol used to send Pan/Tilt/Zoom control over 2-wire shielded twisted pair (STP) terminated with a 100 Ω terminal resistor.

The AutoDome has a 100 Ω termination resistor between the Biphase C+ and C- terminals.



CAUTION!

The Biphase shield must be connected to the head end only.

Cable Type	STP - Shielded Twisted Pair
Distance	1524 m (5000 ft) Belden 8760 recommended
Transmission Rate	31.25 KHz
Gage	1.02 mm (18 AWG)
Termination	100 Ω
Terminal Connector	Screw terminals
Voltage	4 Vp-p

The figure below illustrates the connections necessary for Biphase operation.

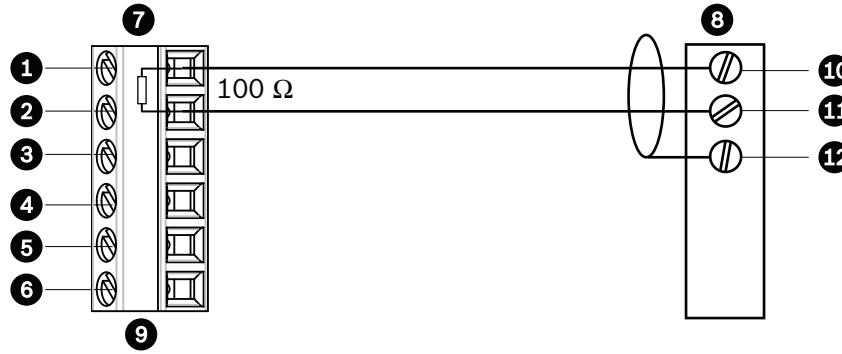

Figure 5.2 Connections for Biphase Operation

1	C- (Biphase)	7	AutoDome Data In/Out
2	C+ (Biphase)	8	Head End Biphase
3	Earth Ground	9	P105/P106 Connector
4	RxD	10	C- (Biphase)
5	TxD	11	C+ (Biphase)
6	Signal Ground	12	Shield

In a daisy chain configuration, where multiple domes are connected in series, the 100 Ω resistor must be removed from all but the last dome. You can daisy chain a maximum of four (4) AutoDomes.

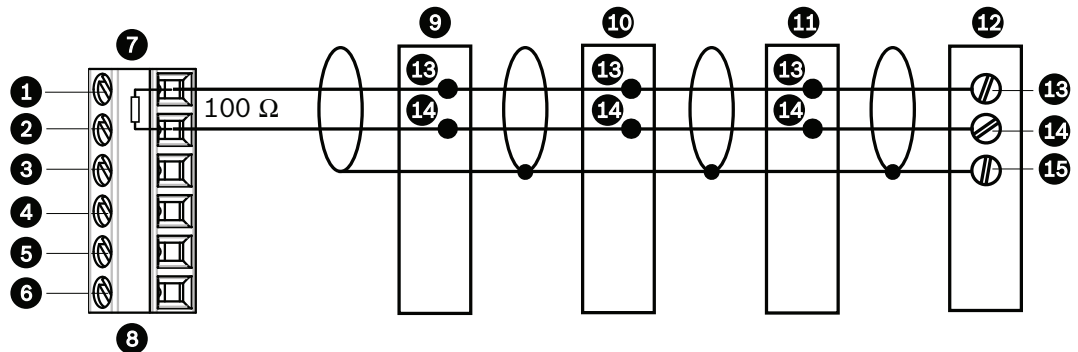

Figure 5.3 Connections for a Daisy Chain Configuration

1	C- (Biphase)	9	Dome 3
2	C+ (Biphase)	10	Dome 2
3	Earth Ground	11	Dome 1
4	RxD	12	Head End Biphase
5	TxD	13	C- (Biphase)
6	Signal Ground	14	C + (Biphase)
7	Last Dome Data In/Out	15	Shield
8	P105/P106 Connector		

RS232 (3-wire, full-duplex, single-ended, 50 ft. cable limit)

RS232 is a common, single-ended communication protocol used for control. Data transmission via 3-wires (TDX, RXD, common) is from one transmitter to one receiver at relatively slow baud rates (up to 57.6 Kbaud) and short distances up to 50 ft.



NOTICE! After making the wire connections for RS232 operation, reposition the slide switch located on the CPU Module to the camera head inward and away from the LEDs.

Wire Type	3-wire (TXD, RXD, common)
Distance	15 m (50 ft)
Maximum Baud Rate	57.6 Kb
Voltage	± 15 V
Termination	100 ?
Slide Switch	Away from LEDs (factory default)

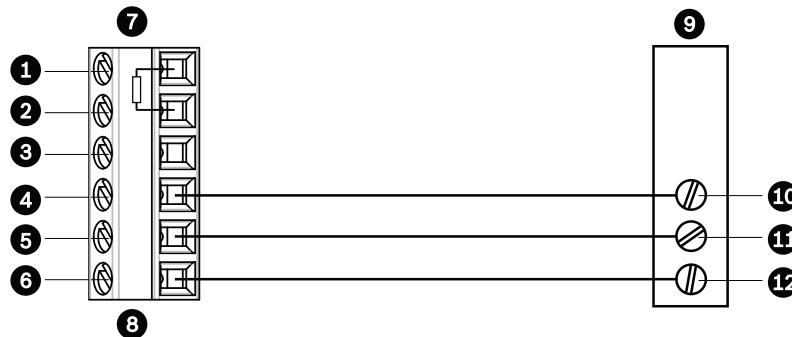

Figure 5.4 Connections for RS232 Operation

1	C- (Biphase)	7	AutoDome Data In/Out
2	C+ (Biphase)	8	P105/P106 Connector
3	Earth Ground	9	Head End RS232
4	RxD	10	TxD
5	TxD	11	RxD
6	Signal Ground	12	Ground

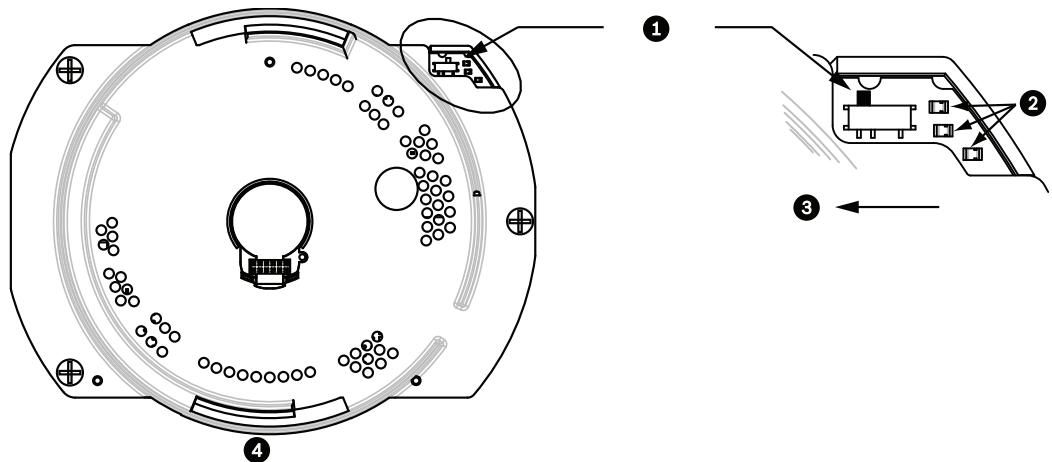

Figure 5.5 Position of CPU Switch for RS232 Operation

1	Switch Location
2	LEDs
3	RS232
4	CPU Module

RS485 (2-wire (shielded), half-duplex, differential, multi-drop (32 nodes), 4000 ft cable limit) RS485 is capable of controlling a true multi-drop network and is specified for up to 32 drivers and 32 receivers on a single 2-wire bus. The AutoDome uses the 2-wire mode, although RS485 can be connected in a 2- or 4-wire mode.



NOTICE!

The wire shield must be tied to signal at both ends, if 2-wire twisted pair is used. After connecting the wires for RS485 operation, make sure the slide switch on the main board to the camera head is positioned toward the LEDs (default).



CAUTION!

Bosch recommends that multiple RS485 connections be arranged as a connected series of point-to-point (multi-dropped) nodes, as a line or as a bus. It is **not** recommended to arrange RS485 connections as a star, ring, or as a multiple-connected network. Star and ring topologies may cause signal reflections or excessively low or high termination impedance.

Wire Type	2-wire shielded twisted pair
Distance	1219 m (4000 ft)
Maximum Baud Rate	57.6 kb
Gage	0.511 mm (24 AWG)
Wire Impedance	120 W
Slide Switch	Toward LEDs (factory default)

The following figure illustrates the connections for RS485 connections.

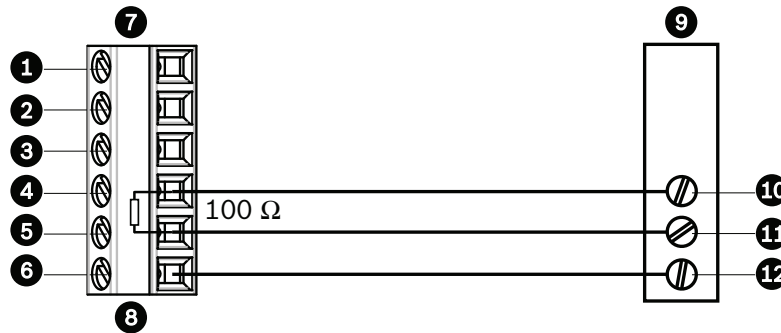

Figure 5.6 Connections for RS485 Operations

1	C- (Biphase)	7	AutoDome Data In/Out
2	C+ (Biphase)	8	P105/P106 Connector
3	Earth Ground	9	Head End RS485
4	RxD	10	Data +
5	TxD	11	Data -
6	Signal Ground	12	Ground

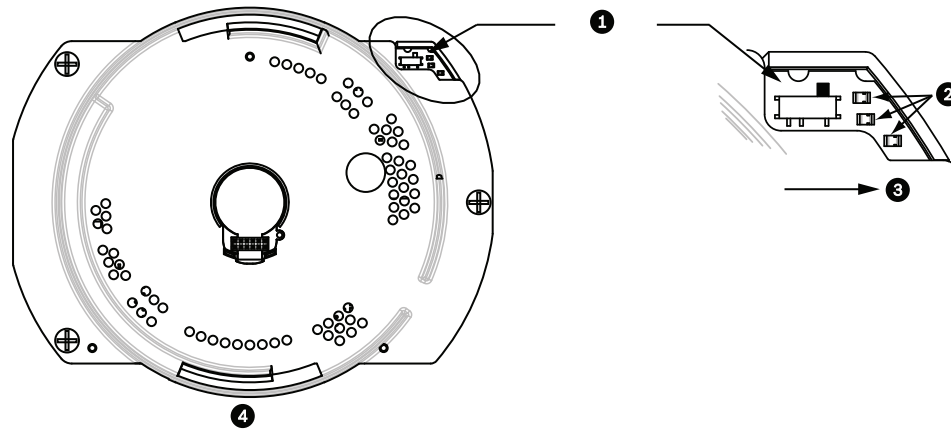

Figure 5.7 Position of CPU Switch for RS485 Operation

1	Switch Location
2	LEDs
3	RS485
4	CPU Module

5.5

Fiber Optic Module with an RS232/RS422 Controller

An AutoDome with a fiber optic module is prewired to operate with Biphase signals only. This section describes the procedures necessary to control a VG4 series AutoDome fitted with a fiber optic kit using an RS232 controller or a Pelco® RS422 controller.

To control a VG4 Series Autodome from an RS232 or from a Pelco RS422 controller you must run control wires from the controller to an LTC 4629 head-end fiber optic module.

5.5.1

Connecting to an LTC 4629 Head End Data/Video Transceiver

1. Connect the RS232 cable (Tx/D from the controller) to the RS232 Rx/D port (pin 1) of the LTC 4629.
2. Connect the ground wire of the controller to Pin 2 on the LTC 4629.

5.5.2 Configuring the VG4 AutoDome

1. Disconnect the power to the VG4 power supply unit; then open the unit.
2. Remove the green Serial Communications wire from the P106 connector.
3. Remove the 100 Ohm resistor across the C+ and C- pins.
4. Cut the five wires from the green Serial Communications wire mating connector. Ensure that the insulation covers each wire to avoid wires from touching.
5. Cut back the insulation on the blue (ground) wire and on the green (RxD) wire enough to be able to connect these wires back into the P106 connector.
6. Connect the blue (ground) wire to the C- pin on the P106 connector.
7. Connect the green (RxD) wire to the C+ pin on the P106 connector.

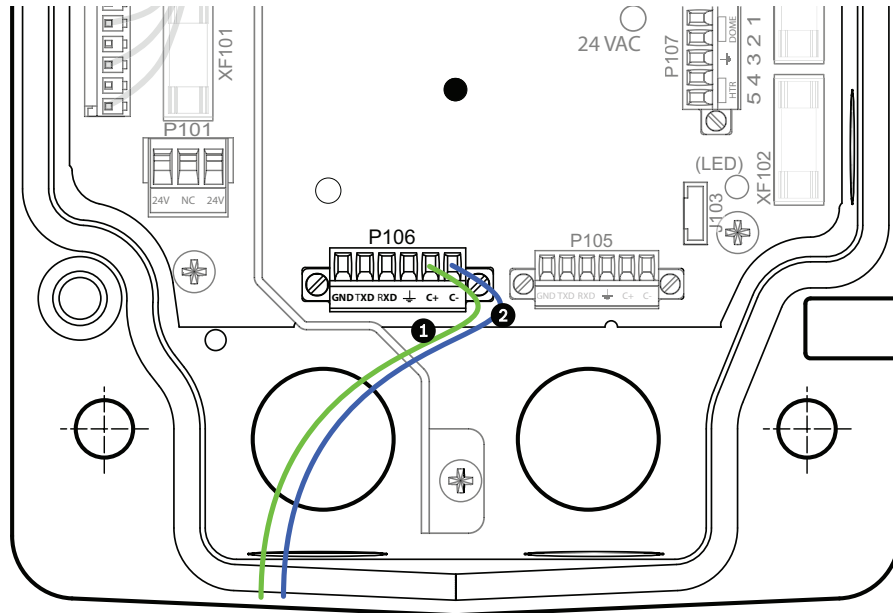

Figure 5.8 Detail of P106 Connections

1	Green RxD wire connected to C+
2	Blue Ground wire connected to C-

8. Connect the fiber optic cable from the AutoDome to the LTC 4629.
9. Close the door to the power supply unit.

10. Ensure that the VG4 AutoDome is set to receive RS232 commands.
 - Remove the bubble from the VG4 AutoDome housing.
 - Locate the protocol switch on the CPU board.
 - Ensure that the protocol switch is in the left position for RS232 operation.

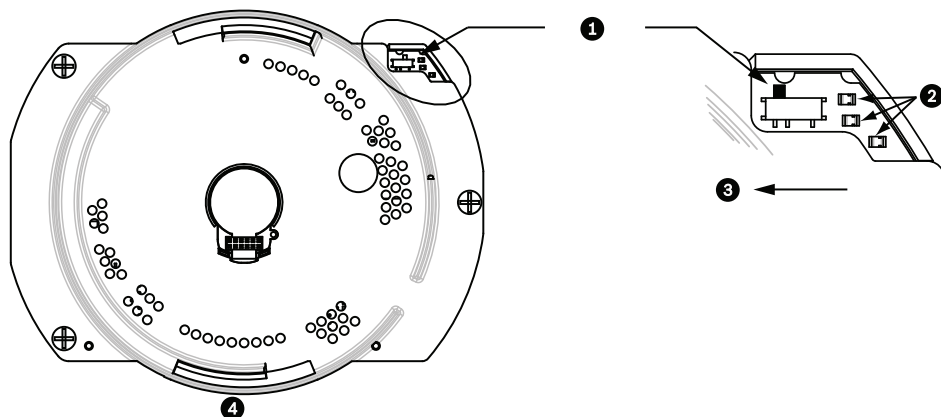

Figure 5.9 Position of CPU Switch for RS232 Operation

1	Switch Location
2	LEDs
3	Move Switch to the left for RS232 Operation
4	CPU Module

11. Return the bubble to the AutoDome housing.
12. Return power to the power supply box.

5.6 Audio Cables

The VG4 AutoDome with Ethernet module is capable of receiving line input audio signals and transmitting it over a network. The audio signal is transmitted one-way and in sync with the video signals.

Audio Line Input Specifications

Max. Input Voltage	5.5 Vpp
Impedance	9K ohm
Sample Rate	8 K Hz, 16 Bit, mono
Shield	Bare copper braid: 95% coverage
Internal gain level adjustment is available	

Wire Specifications

Wire Type	Coax³ (recommended)
Distance	10 m (33 ft)
Gage	22 AWG to Biphase connector (P105/P106)
Shield	Bare copper braid: 95% coverage
Center conductor	Stranded bare copper



NOTICE! Separate the audio cables from the AC power lines to avoid noise.

Audio Connections

1. Remove the 100 ohm termination resistor from the Biphase terminals.
2. Connect the audio line level source to the Biphase C+ input terminal.
3. Connect the audio signal ground to the Biphase C- input terminal.

The following figure illustrates the connections for audio over an IP network

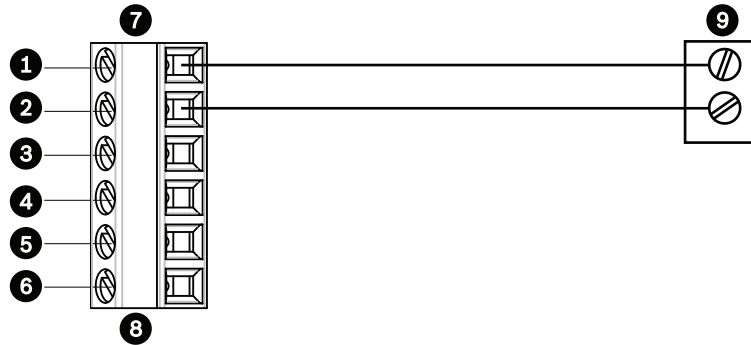

Figure 5.10 Connections for audio over an Ethernet network

1	C- (Biphase)	7	AutoDome Data In/Out
2	C+ (Biphase)	8	P105/P106 Connector
3	Earth Ground	9	Audio Out
4	RxD		
5	TxD		
6	Signal Ground		



NOTICE! See the AutoDome Modular Camera System User Manual for configuring and using audio over an IP Ethernet network.

6 Alarms and Relay Connections

6.1 Alarm Inputs

The AutoDome provides seven alarm inputs. Each input can be activated by dry contact devices such as pressure pads, passive infra-red detectors, door contacts, and similar devices. The table below summarizes the size and distance wires.

Wire Size		Maximum Distance	
AWG	mm	feet	meters
22	0.644	500	152.4
18	1.024	800	243.8

Table 6.1 Alarm wire guide

You wire alarms either Normally Open (N.O.) or Normally Closed (N.C.), and must program the alarm inputs N.O. (the default) or N.C. through the AutoDome main menu.

The AutoDome incorporates two (2) types of alarms: Non-supervised and Supervised. In addition to transmitting an alarm condition, a supervised alarm also transmits a tamper condition. Depending on how the alarm is configured, a short or a break in the alarm's circuit can trigger the tamper signal.

6.2 Configuring Supervised Alarms (inputs 1 and 2)

To configure Alarm 1 or 2 (pin 5 or 6) for supervision, you must install a 2.2 K end-of-line resistor in the circuit. Then, you program the alarms through the AutoDome main menu to either Normally Open Supervised (N.O.S.) or Normally Closed Supervised (N.C.S.).



NOTICE! Only Alarms 1 and 2 (pins 5 or 6) can be configured for supervision. Once a supervised alarm is programmed it does not need to be enabled to indicate a tamper condition.

6.2.1 Configuring a Normally Open Supervised Alarm

1. Install a 2.2 K end-of-line resistor in the alarm circuit.
2. Connect the alarm wires to input 1 or 2 (pin 5 or 6) and to the ground (pin 7) at the AutoDome.

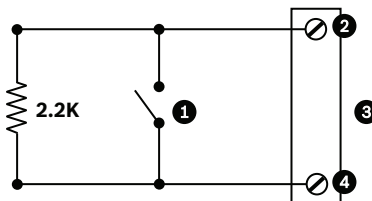

Figure 6.1 N.O.S. - Normally Open Supervised Connections

1	Dry Contact	3	Dome Connector
2	Alarm 1 or 2 only (Pin 5 or 6)	4	Ground (Pin 7)

- From the AutoDome main menu, select Alarms Setup>Inputs Setup, and set the Alarm Input # to N.O.S. See the table below for contact and condition details.

AutoDome Programmed N.O.S.	
Contact	Alarm Condition
Open	Normal
Closed	Alarm
Cut or brake	Tamper

6.2.2

Configuring a Normally Closed Supervised Alarm

- Install a 2.2 K end-of-line resistor in the alarm circuit.
- Connect the alarm wires to input 1 or 2 (pin 5 or 6) and to the ground (pin 7) at the AutoDome.

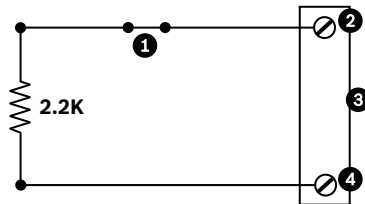

Figure 6.2 N.C.S. - Normally Closed Supervised Connections

1	Dry Contact	3	Dome Connector
2	Alarm 1 or 2 only (Pin 5 or 6)	4	Ground (Pin 7)

- From the AutoDome main menu select Alarm Setup>Inputs Setup, and set Alarm Input # to N.C.S. See the table below for contact and condition details.

AutoDome Programmed N.C.S.	
Contact	Alarm Condition
Open	Alarm
Closed	Normal
Short	Tamper

6.3 Configuring Non-supervised Alarms (inputs 1 through 7)

You can configure alarms 3 through 7 as non-supervised Normally Open (N.O.) or Normally Closed (N.C.) alarms.

6.3.1 Configuring a Normally Open Non-supervised Alarm

1. Connect the alarm to the appropriate input (1 through 7) and ground at the AutoDome.



Figure 6.3 N.O. - Normally Open Non-supervised Connections

1	Dry Contact	3	Dome Connector
2	Alarm Inputs 1 to 7	4	Ground

2. From the AutoDome main menu select Alarm Setup>Inputs Setup, and set Alarm Input # to N.O. See the table below for contact and condition details.

AutoDome Programmed N.O.	
Circuit	Alarm Indication
Open	Normal
Closed	Alarm

6.3.2 Configuring a Normally Closed Non-supervised Alarm

1. Connect the alarm to the appropriate input (1 through 7) and ground at the AutoDome.

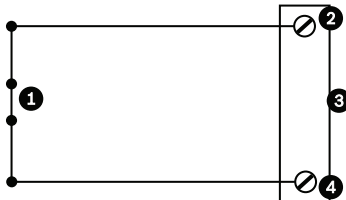

Figure 6.4 N.C. Normally Closed Non-supervised Connections

1	Dry Contact	3	Dome Connector
2	Alarm Inputs 1 to 7	4	Ground

2. From the AutoDome main menu select Alarm Setup>Inputs Setup, and set Alarm Input # to N.C. See the table below for contact and condition details.

AutoDome Programmed N.C.	
Circuit	Alarm Indication
Open	Alarm
Closed	Normal

6.4 Alarm Outputs

The AutoDome incorporates two (2) types of alarm outputs: a dry contact relay and three (3) open collector outputs or transistor outputs.

6.4.1 Configuring a Dry Contact Relay

The dry contact relay acts like an on/off switch. It has a maximum voltage rating of 2 A @ 30 DC.

1. Connect the appropriate stripped wire to the AutoDome COM connector.
2. Connect the appropriate stripped wire to the N.O. or N.C. connector, depending on your requirement.

6.4.2 Configuring an Open Collector Output

Outputs 1, 2, and 3 are open collector types. These outputs must be connected to a positive voltage between 5 and 32 V to complete the circuit, with a maximum voltage rating of 32 VDC @ 150 ma.

1. Connect the appropriate stripped wire to the open connector (1, 2, or 3) of the transistor.
2. Connect the appropriate stripped wire to the ground (GND) connector.

7 Bubble Handling and Cleaning

The bubble is made of Polycarbonate. This material provides high impact resistance. It's optical clarity is comparable to glass or acrylic, although it's surface is much softer. Special care is required when handling and cleaning the bubble to avoid scratching it.

7.1 Handling

The bubble is packaged with a protective plastic sheet. It is recommended that the bubble remain stored this way until it is ready to install. Limit handling the bubble, as any scratches can quickly affect visibility.

7.2 Cleaning

If cleaning the bubble is required, use the following procedures and comply with all the warnings listed below.

7.2.1 Cleaning the Bubble Interior

The extremely soft interior surface should not be cleaned by rubbing or dusting with a cloth. Use clean dry compressed air, preferably from a spray can, to remove any dust from the interior surface.



WARNING!

Do not use alcohol-based solutions to clean the bubble. This will cause the polycarbonate to cloud and over time cause stress aging, which makes the bubble brittle.

7.2.2 Cleaning the Bubble Exterior

The exterior of the bubble is hard coated for extra protection. If cleaning becomes necessary, only use cleaning solutions and cloths suitable for cleaning safety glass lenses. Dry the bubble thoroughly with a dry nonabrasive cloth to prevent water spots. Never scrub the bubble with any abrasive material or cleaners.

Do Not:

- Do Not use abrasive or highly alkaline cleaners on the bubble.
- Do Not scrape the bubble with razor blades or other sharp instruments.
- Do Not use Benzene, Gasoline, Acetone, or Carbon Tetrachloride on the bubble.
- Do Not clean bubbles in the hot sun or on very hot days.

A Installation Notes for AutoTracker

AutoTracker is a feature available with the 500 Series AutoDome. AutoTrack operates by recognizing an individual in motion and zooms-in to approximately 50% of the field of view for an average target height of six feet.

For target acquisition, the focal length must be set correctly, and there needs to be at least 1.2 seconds of valid motion for tracking to initially start.

If you are installing a 500 Series AutoDome and the application requires the use of AutoTrack consider the following notes and refer to the *VG4 200, 300, 500i User's Manual* for more information about setting AutoTracker parameters.

A.1 Camera Height

The height of the AutoDome determines the maximum effective distance that the AutoTracker can track an individual. Bosch recommends a minimum camera height of 3.6 m (12 ft). It is also important to note that the AutoDome will not tilt above the horizon when tracking.

The graph below shows the maximum tracking distance for an AutoDome with a specific camera installed at various heights:

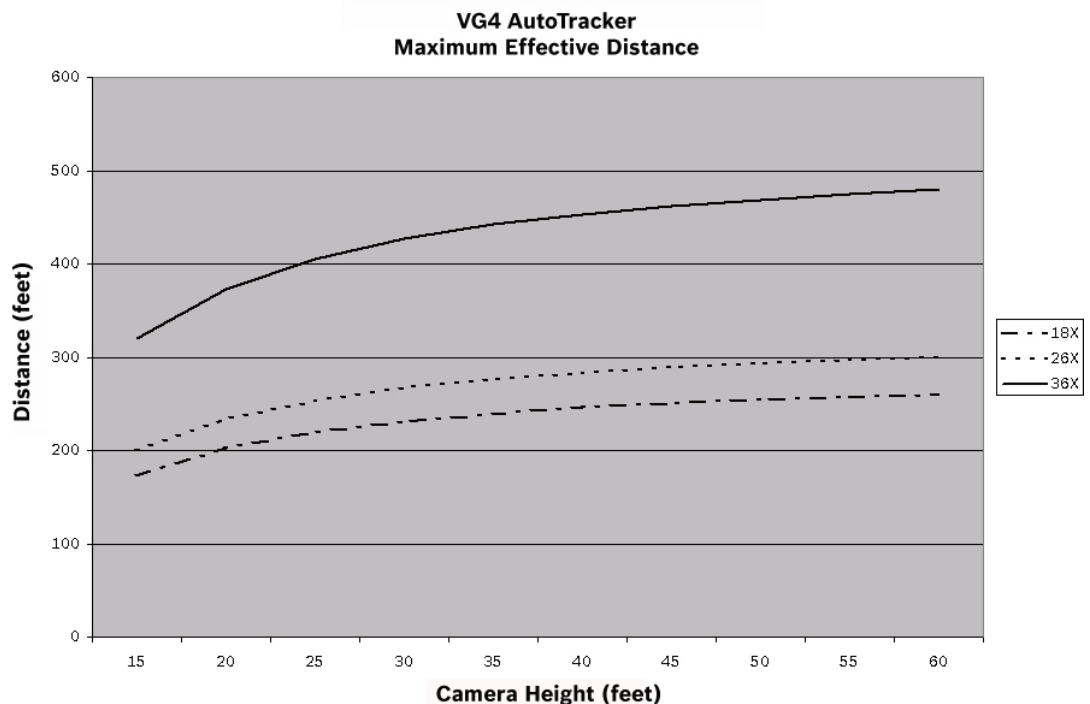

Figure 1.1 Maximum AutoTracker distance for a camera at a certain height

The chart below provides more detail for maximum AutoTracker distances at specific camera heights for the three camera options:

Camera Height	Maximum AutoTracker Distance		
	18X	26X	36X
4.5 m (15 ft)	52.7 m (173 ft)	61.0 m (200 ft)	97.5 m (320 ft)
6.1 m (20 ft)	61.6 m (202 ft)	71.0 m (233 ft)	113.7 m (373 ft)
9.1 m (30 ft)	70.4 m (231 ft)	81.4 m (267 ft)	130.2 m (427 ft)
12.2 m (40 ft)	75.0 m (246 ft)	86.3 m (283 ft)	138.1 m (453 ft)
15.2 m (50 ft)	77.4 m (254 ft)	89.3 m (293 ft)	143.0 m (469 ft)
18.3 m (60 ft)	79.2 m (260 ft)	91.4 m (300 ft)	146.3 m (480 ft)

A.2 Mount/Mounting Surfaces

- Mount the camera in the most stable position. Avoid locations affected by vibrations, such as those caused by a roof-top air conditioner. These vibrations may cause complications when the camera zooms-in on a target.
- Use the pendant arm mount, if possible. This mount option provides the most stability for the camera.
- Use guy wires to protect against strong winds if using the parapet mount.

A.3 Field of View

- Select a location and viewing angle that allows the flow of people to move across the camera's field of view.
- Avoid motion that moves directly towards the camera.
- Avoid locations that attract large numbers of people, such as retail stores or intersections.

A.4 Unwanted Motion

- Use the Virtual Masking feature (see chapter 7 in the *VG4 200,300,500i Series User Manual*) to mask unwanted motion from trees or cars.
- Bosch recommends that you draw the virtual mask 10% larger than the object to be masked.
- Avoid neon lights, flashing lights, night time lights, and reflected light (from a window or mirror, for example). The flickering of these lights can affect the AutoTrack operation. Use a Virtual Mask to hide these type of lights if they cannot be avoided.
- Check the virtual mask periodically to ensure that it still covers the entire object to be masked. Adjust the mask if necessary.

Index

A

- alarm connectors 19
- alarm inputs 96
 - dry contact relay 99
 - non-supervised 98
 - normally closed non-supervised 98
 - normally closed supervised 97
 - normally open non-supervised 98
 - normally open supervised 96
 - supervised 96
 - with in-ceiling mount 79
 - with parapet roof or pipe mounts 59
 - with pendant arm, corner or mast mount 19, 26, 31
- alarm outputs 99
 - open collector output 99
 - with in-ceiling mount 79
 - with parapet roof or pipe mount 59
 - with pendant arm, corner or mast mount 19, 26, 31
- attaching
 - bubble 31, 83
 - cover door 46
 - in-ceiling mount 81
 - pendant arm 24
- AutoTracker 101
 - camera height 101
 - field of view recommendations 102
 - mounting surface 102

B

- banding tool 15, 17, 27
- Bilinx 85
- biphase 18, 87, 88
- BNC connector
 - with pendant arm, corner or mast mount 18
 - with roof parapet or pipe mount 58
- bracket assembly 76, 77
- bubble 100
 - cleaning 100
 - handling 100
 - release aperture 84
 - roof parapet or pipe mount 60
- bubble assembly 61

C

- cable compensation 85
- cable standards 85
- cables
 - copper 85
 - fiber optic 87
- camera height 101
- camera module 61
- coaxial cable 85
- communication protocol
 - RS232 90
- control data I/O plug 18
- copper wire 85
- corner installation 17, 27
- corner plate 17
- cover door 46

D

- daisy chaining 18, 89
- dome bubble 83
- dome cap 54
- drywall ceiling 75

E

- Ethernet 78, 87

F

- fiber optic 87
 - module 26
 - multimode 87
 - single mode 87, 88
 - with pendant arm, corner or mast mount 18
 - with roof parapet or pipe mount 49
- fuse specifications 20

G

- guy-wire 55

H

- housing
 - pressurized environmental 35, 65
 - securing 82

I

- in-ceiling
 - parts 74
- in-ceiling mount 73
 - attaching housing 81
 - installing camera module 83
 - interface box connections 80
 - parts 73
 - securing to ceiling 82
- installing
 - in-ceiling mount 73
 - pendant arm, corner or mast mount 13
 - pipe interface board 60
 - pipe mount 55
 - pressurized environmental housing 35, 65
 - roof parapet mount 52
 - tope-mounting flange 55
- interface box 78, 80, 81

L

- locking tab 32
- LTC 9230/01 53

M

- mast installation 17, 27
- mast plate 17
- maximum distances 85
- mount
 - in-ceiling 73
 - pendant arm, corner or mast 13
 - pipe 42
 - roof parapet 42
- Mounting Plate 16, 27

N

- NEMA Certification
 - for pendant arm, corner or mast mount 15
 - for roof parapet or pipe mount 44
- non-supervised alarms 98

P

- parapet arm
 - stabilizing 55
- parts
 - pendant arm wall, corner or mast 14
- pendant
 - connector harness 27, 31
- pendant arm
 - attaching to power supply box 24
- pendant arm, corner or mast mount
 - mast plate 17
- pendant assembly 31
 - attaching to pipe mount 62, 67
 - bubble 31, 60
 - camera module 31, 60
 - for roof parapet or pipe mount 60
 - housing 60
 - locking tab 32
- pendant bubble
 - removing 34, 41, 64, 72
- pipe interface board 57, 60
- pipe mount 42, 55
 - power supply box location 44
- pole installation 17, 27
- power supply
 - fuse specifications 20
 - with fiber optic model 63, 68
- power supply box 47
 - attaching to pendant arm 24
 - connections for pendant arm 21, 22
 - connections for roof parapet or pipe mount 42, 51, 63, 68
 - daisy chaining 18
 - installing with in-ceiling mount 75
 - installing with pendant arm, corner or mast mount 16, 25
 - installing with roof parapet or pipe mount 45
 - locating for pendant arm, corner or mast mount 15
 - wiring for pendant arm, corner or mast mount 25
- Pre-Comp 85
- preparing
 - drywall ceiling 75
 - suspension ceiling 76
- pressurized environmental housing
 - calibrating 38, 69
 - installing 35, 65
 - pendant arm, corner, or mast mount 35
 - roof parapet or pipe mount 65
- protocol
 - RJ45 78

R

- relay 99
- relay connectors 19
- RJ45 78
- roof parapet or pipe mount 42, 52
 - cover door 46
 - dome cap 54
 - fiber optic model 63, 68
 - parts 42
 - power supply box location 44
 - wall bracket 53
 - wall mount bracket 52
- routing wires
 - for in-ceiling mount 78
 - for pendant arm, corner or mast mount 17
 - for roof parapet or pipe mount 47
- RS232 90
- RS485 91
- S**
- supervised 96
- suspension ceiling 76
- T**
- top-mounting flange 55
- trim skirt 16
- U**
- unshielded twisted pair 78
 - with in-ceiling mount 78
 - with pendant arm, corner or mast mount 18
- unshielded twisted pair (UTP) 86
- UTP CAT-5 87
- V**
- VG4-A-9230 44, 52
- VG4-ARMPLATE 16, 27
- W**
- wall installation 17
- wall mount template 16
 - for roof parapet or pipe mount 45
- wire standards 85
- wiring
 - for in-ceiling mount 75, 78
 - for interface box 78
 - for pendant arm, corner or mast mount 15
 - for pipe interface board 57
 - for roof parapet or pipe mount 49
 - power supply box 47

Bosch Security Systems, Inc.

850 Greenfield Road
Lancaster, PA 17522

U.S.A.

Phone +1 888-289-0096

Fax +1 585-223-9180

www.boschsecurity.com

© Bosch Security Systems, Inc. , 2010